

## High Performance Step-Down DC/DC Controller with High-Resolution True DC Dimming for LED Lighting up to 78V

### 1 Description

The iW380 is a DC/DC step-down controller with tight current regulation and exceptional dimming performance for LED lighting. It is designed to be used in the high-side switching buck topology up to 78V input voltage and up to 98% of output voltage/input voltage ratio. With its advanced digital control, the iW380 offers Dialog's True DC Dimming from 100% down to 0.0625% with 0.0625% resolution and guaranteed linearity.

The iW380 features unique dual-dimming pins that significantly simplify application designs where multi-level maximum current settings are needed. The maximum LED current can be programmed through one dimming pin via the analog voltage level or an adjustable resistor. The other dimming port can be used for auto-detectable 3-in-1 dimming: analog voltage, PWM duty or resistor dimming. Internally, the iW380 processes the dimming inputs and regulates the output current percentage by  $DIM1\% \times DIM2\%$ .

A dedicated light-off mode in the iW380 turns off the output current when the dimming signal input is less than the light-off threshold. In the light-off mode, the iW380 consumes minimum power while still monitoring the dimming inputs. If the dimming signal input becomes higher than the light-on threshold, the iW380 can immediately wake up and resume output current regulation.

The iW380 provides flexibility to optimize dimming resolution and dimming signal noise immunity. When a noisy analog dimming level or jittering PWM dimming duty is supplied to the iW380, the iW380 can keep the output current stable with some tradeoff to dimming resolution by configuration. Also, the iW380 has configurable minimum startup voltage. This feature can effectively prevent light flicker/flash at power off across different applications.

### 2 Features

- Input DC voltage range: 22V ~ 78V
- Output/input voltage ratio: up to 98%
- Output power up to 150W
- Multiple operating mode product options:
  - Constant-current (CC) mode
  - Constant-voltage/constant-current (CV/CC) mode
  - Constant-power/constant-current (CP/CC) mode
- True DC dimming
  - Max dimming range: 0.0625% ~ 100%
  - Highest dimming resolution: 0.0625%
- CC line and load regulation  $< \pm 3\%$
- CV line and load regulation  $< \pm 3\%$
- Light-off current consumption  $< 1\text{mA}$
- Over temperature current de-rating
- 3-in-1 dimming on both dimming ports
  - RSET resistor
  - PWM Dimming
  - Analog voltage
- Auto dimming signal types detection
- Configurable dimming signal hysteresis
- Configurable startup voltage
- Rich protections:
  - Output over voltage (OVP)
  - Output short circuit (OSP)
  - $V_{VIN}$  over/under voltage
  - Over current protection (OCP)
  - Sense resistor short protection
  - Over temperature protection (OTP)

### 3 Applications

- Two-stage AC/DC general LED lighting drivers
- Two-stage AC/DC LED light strip drivers
- DC/DC general LED lighting drivers

High Performance Step-Down DC/DC Controller with High-Resolution True DC Dimming for LED Lighting up to 78V

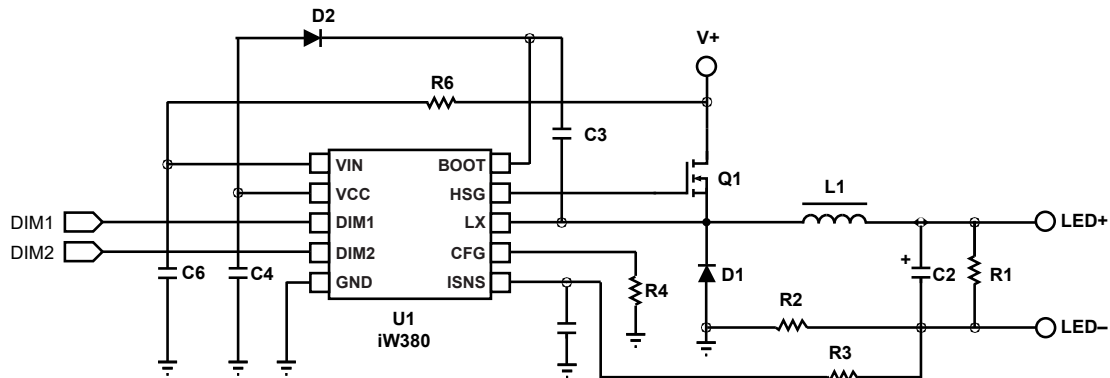

Figure 3.1 : iW380 Typical Application Circuit for CC only and CP/CC variants

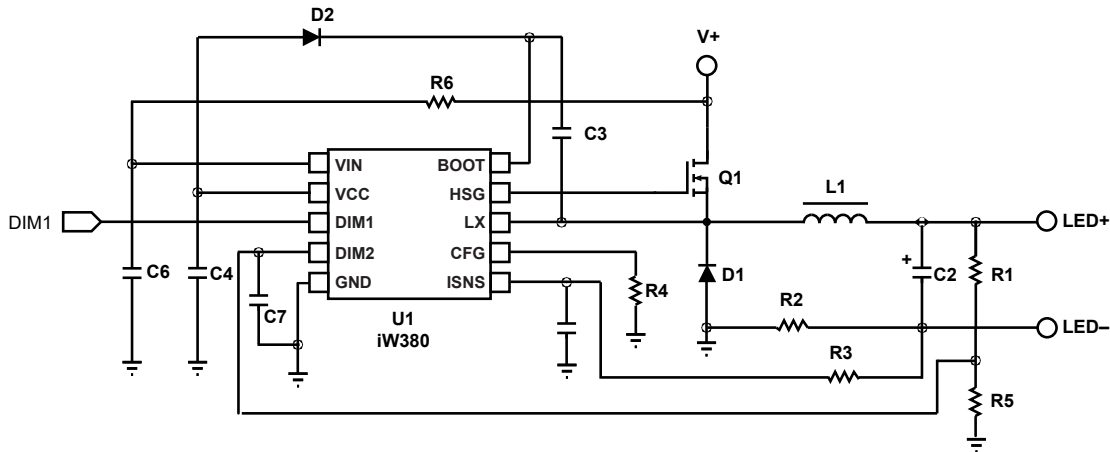

Figure 3.2 : iW380 Typical Application Circuit for CV/CC variants

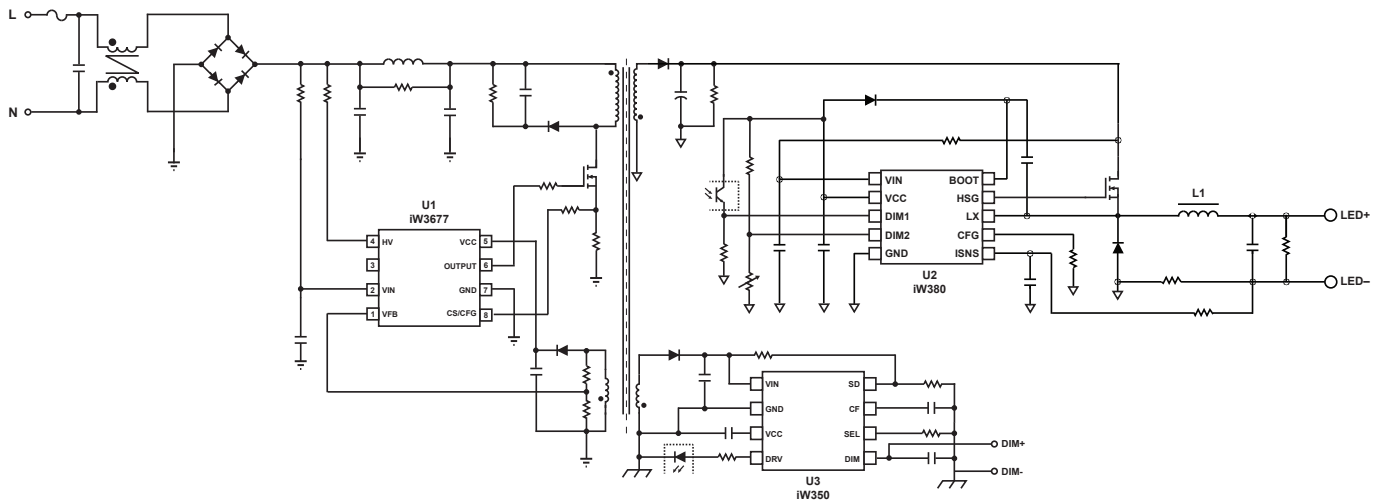

Figure 3.3 : iW380 Dimmable LED Driver Application with iW3677 Front-End Power Factor Correction Flyback and iW350 Interface IC

## High Performance Step-Down DC/DC Controller with High-Resolution True DC Dimming for LED Lighting up to 78V

### 4 Pinout Description

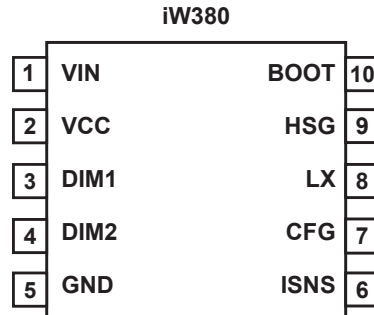

Figure 4.1 : 10-Lead SOIC Package

Pin Number	Pin Name	Type	Pin Description
1	VIN	Power	Power source and input voltage sensing
2	VCC	Power	IC power supply
3	DIM1	Analog Input	Dimming signal input port 1
4	DIM2	Analog Input	Dimming signal input port 2
5	GND	Ground	Ground reference
6	ISNS	Analog Input	Buck inductor current sensing
7	CFG	Analog Input	Configuration input
8	LX	Analog Input	Buck switching node, high-side power MOSFET source
9	HSG	Analog Output	High-side power MOSFET gate drive
10	BOOT	Power	Bootstrap high-side driver power supply

## High Performance Step-Down DC/DC Controller with High-Resolution True DC Dimming for LED Lighting up to 78V

### 5 Absolute Maximum Ratings

Absolute maximum ratings are the parameter values or ranges which can cause permanent damage if exceeded.

Parameter	Symbol	Value	Units
DC supply voltage range	$V_{VCC}$	-0.3 to 6.5	V
Continuous DC supply at VCC pin	$I_{VCC}$	20	mA
VIN pin		-0.3 to 82	V
DIM1 and DIM2 pin		-0.3 to 6.5	V
ISNS pin		-0.3 to 6.5	V
CFG pin		-0.3 to 6.5	V
LX pin		-0.7 to 82	V
HSG pin (Note 1)		-0.3 to 87	V
BOOT pin (Note 1)		-0.3 to 87	V
Maximum junction temperature	$T_{JMAX}$	150	°C
Operating junction temperature	$T_{JOPT}$	-40 to 150	°C
Storage temperature	$T_{STG}$	-65 to 150	°C
Thermal resistance junction to ambient	$\theta_{JA}$	100	°C/W
ESD rating per JEDEC JS-001-2017		±2000	V
Latch-up test per JESD78E		±100	mA

**Note 1.** BOOT pin and HSG pin respect to LX pin < 5.5V.

# High Performance Step-Down DC/DC Controller with High-Resolution True DC Dimming for LED Lighting up to 78V

## 6 Physical Dimensions

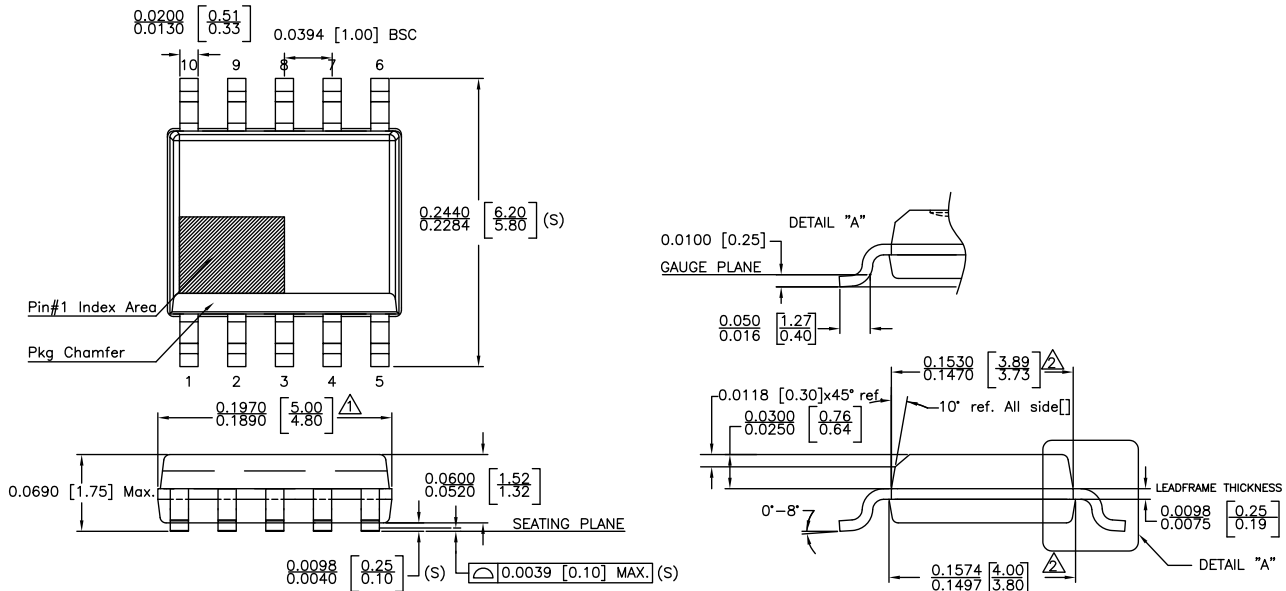

**NOTE :**

- △ DOES NOT INCLUDE MOLD FLASH, PROTRUSIONS OR GATE BURRS. MOLD FLASH, PROTRUSIONS AND GATE BURRS SHALL NOT EXCEED .006 INCH PER SIDE.
- △ DOES NOT INCLUDE INTER-LEAD FLASH OR PROTRUSIONS. INTER-LEAD FLASH AND PROTRUSIONS SHALL NOT EXCEED .010 INCH PER SIDE.
- 3. PACKAGE DIMENSION CONFORM TO JEDEC SPECIFICATION MS-012 EXCEPT LEAD PITCH.
- 4. LEAD SPAN/STAND OFF HEIGHT/COPLANARITY ARE CONSIDERED AS SPECIAL CHARACTERISTIC.(S)
- 5. CONTROLLING DIMENSIONS IN INCHES.[mm]
- 6. PHYSICAL APPEARANCE OF PACKAGE (E-PIN, DIMPLE, CHAMFER) MAY VARY DUE TO ASSEMBLY TOOLINGS

STATUS:	RELEASED
TERMINAL FINISH:	PPF or 100% Sn
TITLE:	SOP 10L 150MIL PACKAGE OUTLINE
REV:	REVISION NOTE:
C	STANDARDIZED POD

Figure 6.1 : 10-Lead SOIC Package Outline Drawing

## 7 Ordering Information

Part Number	Options	Package	Description
iW380-00	CC only	SOIC-10	Tape & Reel <sup>1</sup>
iW380-01	CC only, 0.3125% lowest dimming startup threshold	SOIC-10	Tape & Reel <sup>1</sup>
iW380-20	CV/CC variant, DIM2 as feedback	SOIC-10	Tape & Reel <sup>1</sup>
iW380-30	CP/CC variant, CP constant = 50%	SOIC-10	Tape & Reel <sup>1</sup>
iW380-31	CP/CC variant, CP constant = 70%	SOIC-10	Tape & Reel <sup>1</sup>

Note 1. Tape and reel packing quantity is 2,500/reel. Minimum packing quantity is 2,500.

## High Performance Step-Down DC/DC Controller with High-Resolution True DC Dimming for LED Lighting up to 78V

### Disclaimer

Unless otherwise agreed in writing, the Dialog Semiconductor products (and any associated software) referred to in this document are not designed, authorized or warranted to be suitable for use in life support, life-critical or safety-critical systems or equipment, nor in applications where failure or malfunction of a Dialog Semiconductor product (or associated software) can reasonably be expected to result in personal injury, death or severe property or environmental damage. Dialog Semiconductor and its suppliers accept no liability for inclusion and/or use of Dialog Semiconductor products (and any associated software) in such equipment or applications and therefore such inclusion and/or use is at the customer's own risk.

Information in this document is believed to be accurate and reliable. However, Dialog Semiconductor does not give any representations or warranties, express or implied, as to the accuracy or completeness of such information. Dialog Semiconductor furthermore takes no responsibility whatsoever for the content in this document if provided by any information source outside of Dialog Semiconductor.

Dialog Semiconductor reserves the right to change without notice the information published in this document, including, without limitation, the specification and the design of the related semiconductor products, software and applications. Notwithstanding the foregoing, for any automotive grade version of the device, Dialog Semiconductor reserves the right to change the information published in this document, including, without limitation, the specification and the design of the related semiconductor products, software and applications, in accordance with its standard automotive change notification process.

Applications, software, and semiconductor products described in this document are for illustrative purposes only. Dialog Semiconductor makes no representation or warranty that such applications, software and semiconductor products will be suitable for the specified use without further testing or modification. Unless otherwise agreed in writing, such testing or modification is the sole responsibility of the customer and Dialog Semiconductor excludes all liability in this respect.

Nothing in this document may be construed as a license for customer to use the Dialog Semiconductor products, software and applications referred to in this document. Such license must be separately sought by customer with Dialog Semiconductor.

All use of Dialog Semiconductor products, software and applications referred to in this document is subject to Dialog Semiconductor's [Standard Terms and Conditions of Sale](#), available on the company website ([www.dialog-semiconductor.com](http://www.dialog-semiconductor.com)) unless otherwise stated.

Dialog, Dialog Semiconductor and the Dialog logo are trademarks of Dialog Semiconductor Plc or its subsidiaries. All other product or service names and marks are the property of their respective owners.

© 2021 Dialog Semiconductor. All rights reserved.

### RoHS Compliance

Dialog Semiconductor's suppliers certify that its products are in compliance with the requirements of Directive 2011/65/EU of the European Parliament on the restriction of the use of certain hazardous substances in electrical and electronic equipment. RoHS certificates from our suppliers are available on request.

## Contacting Dialog Semiconductor

**United Kingdom (Headquarters)**  
Dialog Semiconductor (UK) LTD  
Phone: +44 1793 757700

**Germany**  
Dialog Semiconductor GmbH  
Phone: +49 7021 805-0

**The Netherlands**  
Dialog Semiconductor B.V.  
Phone: +31 73 640 8822

**Email**  
[info\\_pcbg@diasemi.com](mailto:info_pcbg@diasemi.com)

**North America**  
Dialog Semiconductor Inc.  
Phone: +1 408 845 8500

**Japan**  
Dialog Semiconductor K. K.  
Phone: +81 3 5769 5100

**Taiwan**  
Dialog Semiconductor Taiwan  
Phone: +886 281 786 222

**Web site:**  
[www.dialog-semiconductor.com](http://www.dialog-semiconductor.com)

**Hong Kong**  
Dialog Semiconductor Hong Kong  
Phone: +852 2607 4271

**Korea**  
Dialog Semiconductor Korea  
Phone: +82 2 3469 8200

**China (Shenzhen)**  
Dialog Semiconductor China  
Phone: +86 755 2981 3669

**China (Shanghai)**  
Dialog Semiconductor China  
Phone: +86 21 5424 9058