

## RapidCharge™ AC/DC Primary-Side Digital ZVS Flyback Controller

### 1 Description

The iW9801 is a high-performance AC/DC primary-side digital flyback controller with advanced zero-voltage-switching (ZVS) and adaptive multi-mode-control (MMC) working with secondary-side regulation (SSR) for applications requiring high power density and high resolution in output voltage/current setting. The device can support rapid charge applications such as travel adapters (TA) of 25W and above. It operates under multi-mode control (MMC) including PWM, PFM and burst mode with main switch ZVS turn-on at high line voltage to achieve less switching loss and low EMI. It also provides a number of key built-in protection features.

The iW9801 is optimized to work with Dialog's secondary-side controller, the iW70x, for SSR, synchronous rectifier (SR) control and USB PD 3.0 with PPS protocol support. The iW9801/iW70x chipset can achieve tight multi-level constant voltage (CV) and multi-level constant current (CC) regulation in very fine steps for rapid charge applications. With SSR digital compensation, the chipset eliminates the need for external loop compensation components while maintaining stability under all operating conditions.

The iW9801 and iW70x chipset can support USB PD 3.0 with PPS to achieve fast and smooth CV/CC transitions upon request by mobile devices (MD). The iW9801 and iW70x chipset can meet no-load power consumption of less than 20mW for a typical 25W to 45W design when the output USB cable is detached.

Dialog's innovative proprietary technology ensures that power supplies designed with the iW9801 and iW70x chipset can achieve high efficiency, high accuracy voltage/current control and fast dynamic load response.

### 2 Features

- Supports USB PD travel adapter (TA) applications of 35W and above
- Supports constant-voltage (CV) and constant-current (CC) regulation in fine steps by secondary-side regulation (SSR)
- Dialog's patented adaptive ZVS control enables high efficiency and low EMI
- User configurable ZVS timing to optimize performance for different power MOSFETs
- Adaptive multi-mode control (MMC) using PWM/PFM/Burst modes based on input voltage and output voltage/current improves efficiency and eliminates audible noise
- Built-in single-point fault protections against AC line voltage brown-out, output short-circuit, output over-voltage, and optocoupler failure
- User programmable internal over-temperature protection (OTP) threshold for various thermal requirement
- < 20mW no load standby power for typical 25W to 45W designs at 230V<sub>AC</sub> when output USB cable is detached
- AC unplug detection and X-capacitor discharge control
- 10-lead SOIC package

### 3 Applications

- Rapid-charging AC/DC adapters for smart phones, tablets and other portable devices

RapidCharge™ AC/DC Primary-Side Digital ZVS Flyback Controller

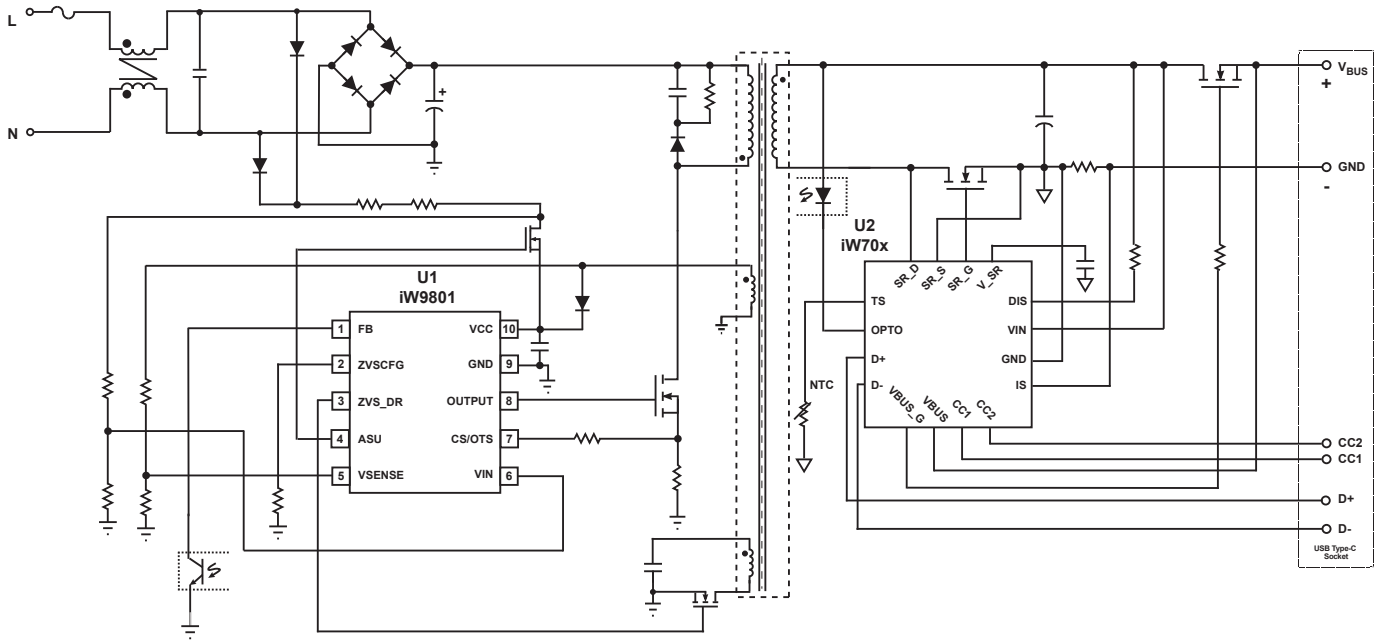

Figure 3.1 : iW9801 Typical Application Circuit with Active Start-up Circuit  
(Using iW70x as Secondary-Side Controller. Achieving Multi-Level CV/CC Regulation)

## RapidCharge™ AC/DC Primary-Side Digital ZVS Flyback Controller

### 4 Pinout Description

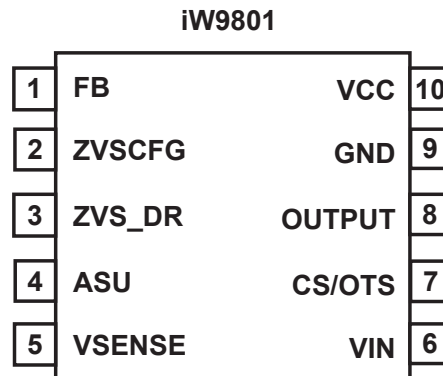

Figure 4.1 : 10-Lead SOIC Package

Pin Number	Pin Name	Type	Pin Description
1	FB	Analog Input	Feedback voltage. Used for determining multi-mode control and cycle-by-cycle peak current control.
2	ZVSCFG	Analog Input	ZVS timing configuraton. Used for fine-tuning of ZVS auxiliary switch turn-on time.
3	ZVS_DR	Analog Output	Gate drive for auxiliary MOSFET for ZVS purpose.
4	ASU	Analog Output	Control Signal. Used for active start-up device (BJT or depletion mode N-FET)
5	VSENSE	Analog Input	Voltage sensing. Used for output voltage sensing and auxiliary winding ringing voltage sensing.
6	VIN	Analog Input	Input AC line voltage detection. Used for AC line voltage detection and AC unplug detection for X-capacitor discharge.
7	CS/OTS	Analog Input	Current sensing. Used for cycle-by-cycle peak-current control and limit. During configuration stage, it can be used to configure certain parameters, such as internal over-temperature protection setting.
8	OUTPUT	Analog Output	Gate drive for power MOSFET.
9	GND	Ground	Ground.
10	VCC	Power Input	IC power supply.

## RapidCharge™ AC/DC Primary-Side Digital ZVS Flyback Controller

### 5 Absolute Maximum Ratings

Absolute maximum ratings are the parameter values or ranges which can cause permanent damage if exceeded. For maximum safe operating conditions, refer to Electrical Characteristics in Section 6.

Parameter	Symbol	Value	Units
DC supply voltage range	$V_{VCC}$	-0.3 to 45	V
Continuous DC supply current at VCC pin ( $V_{VCC} = 15V$ )	$I_{VCC}$	20	mA
VSENSE input ( $I_{VSENSE} \leq 10mA$ )		-0.7 to 10	V
FB voltage		-0.3 to 5.0	V
ZVSCFG voltage		-0.3 to 5.5	V
ZVS_DR voltage		-0.3 to 20	V
VIN voltage		-0.3 to 5.0	V
ASU voltage		-0.3 to 45	V
CS/OTS voltage		-0.3 to 5.5	V
OUTPUT voltage		-0.3 to 20	V
Maximum junction temperature	$T_{JMAX}$	150	°C
Operating junction temperature	$T_{JOPT}$	-40 to 150	°C
Storage temperature	$T_{STO}$	-65 to 150	°C
Thermal Resistance Junction-to-Ambient	$\theta_{JA}$	160	°C/W
ESD rating per JEDEC JS-001-2017		$\pm 2,000$	V
Latch-up test per JESD78E		$\pm 100$	mA

#### Notes:

- Note 1. Stresses beyond those listed under Absolute Maximum Ratings may cause permanent damage to the device. These are stress ratings only, so functional operation of the device at these or any other conditions beyond those indicated in the operational sections of the specification are not implied. Exposure to absolute maximum rating conditions for extended periods may affect device reliability.

### 6 Physical Dimensions

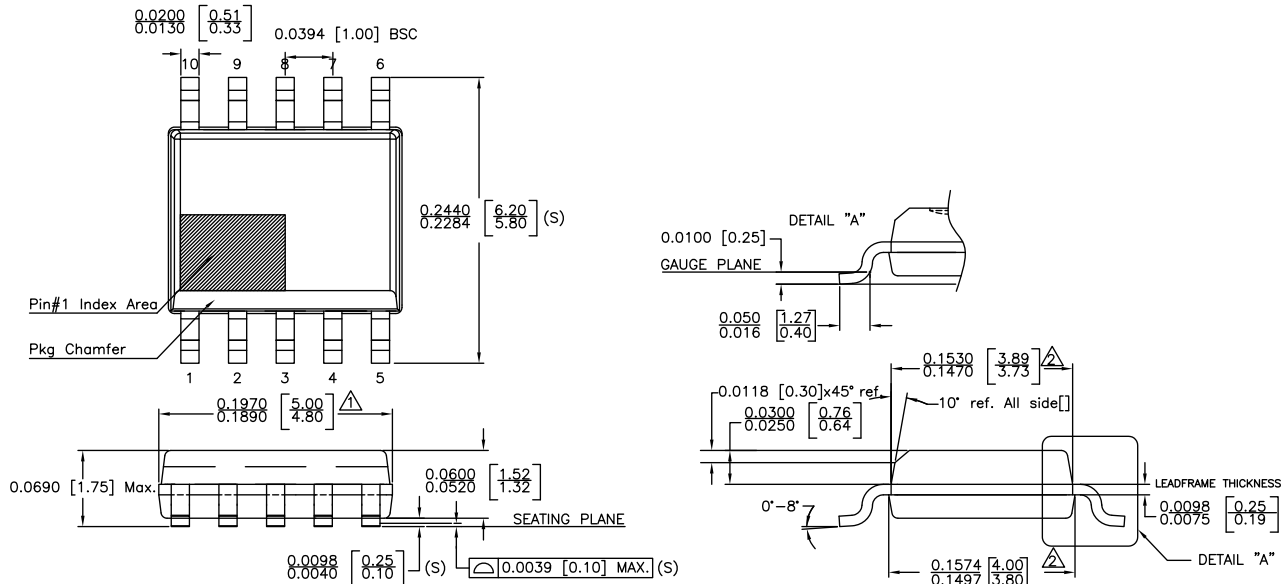

**NOTE :**

- △ DOES NOT INCLUDE MOLD FLASH, PROTRUSIONS OR GATE BURRS. MOLD FLASH, PROTRUSIONS AND GATE BURRS SHALL NOT EXCEED .006 INCH PER SIDE.
- △ DOES NOT INCLUDE INTER-LEAD FLASH OR PROTRUSIONS. INTER-LEAD FLASH AND PROTRUSIONS SHALL NOT EXCEED .010 INCH PER SIDE.
- 3. PACKAGE DIMENSION CONFORM TO JEDEC SPECIFICATION MS-012 EXCEPT LEAD PITCH.
- 4. LEAD SPAN/STAND OFF HEIGHT/COPLANARITY ARE CONSIDERED AS SPECIAL CHARACTERISTIC.(S)
- 5. CONTROLLING DIMENSIONS IN INCHES.[mm]
- 6. PHYSICAL APPEARANCE OF PACKAGE (E-PIN, DIMPLE, CHAMFER) MAY VARY DUE TO ASSEMBLY TOOLINGS

STATUS:	RELEASED
TERMINAL FINISH:	PPF or 100% Sn
TITLE:	SOP 10L 150MIL PACKAGE OUTLINE
REV:	REVISION NOTE: C STANDARDIZED POD

Figure 6.1 : 10-Lead SOIC Package Outline Drawing

### 7 Ordering Information

Part no.	Options							Package	Description
	V <sub>BUS</sub> range	CCM	ZVS	F <sub>SW(MAX)</sub> at low line	F <sub>SW(MAX)</sub> at high line	V <sub>BUS</sub> /V <sub>SENSE</sub>	X-cap discharge		
iW9801-00	3.3V to 21V	No	Yes at high line	100kHz	95kHz	1:0.7	Yes	SOIC-10	Tape & Reel <sup>1</sup>
iW9801-06	3.3V to 21V	Yes	Yes at high line	110kHz	95kHz	1:0.7	Yes	SOIC-10	Tape & Reel <sup>1</sup>
iW9801-07	3.3V to 21V	No	Yes at high line	140kHz	130kHz	1:0.7	Yes	SOIC-10	Tape & Reel <sup>1</sup>

Note 1: Tape & Reel packing quantity is 2,500/reel. Minimum packing quantity is 2,500.

RapidCharge™ AC/DC Primary-Side Digital ZVS Flyback Controller

8 Top Marking

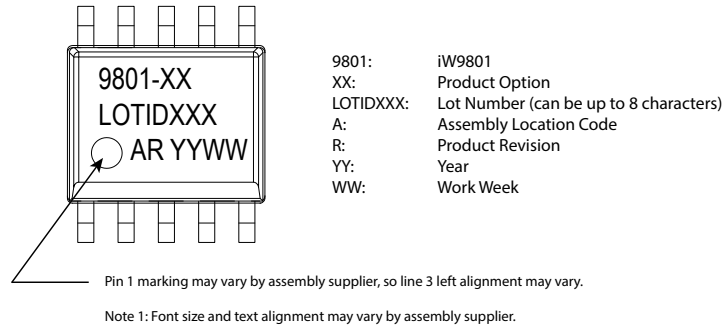

Figure 8.1 : Top Marking for the iW9801 (SOIC-10)

## RapidCharge™ AC/DC Primary-Side Digital ZVS Flyback Controller

### Disclaimer

Unless otherwise agreed in writing, the Dialog Semiconductor products (and any associated software) referred to in this document are not designed, authorized or warranted to be suitable for use in life support, life-critical or safety-critical systems or equipment, nor in applications where failure or malfunction of a Dialog Semiconductor product (or associated software) can reasonably be expected to result in personal injury, death or severe property or environmental damage. Dialog Semiconductor and its suppliers accept no liability for inclusion and/or use of Dialog Semiconductor products (and any associated software) in such equipment or applications and therefore such inclusion and/or use is at the customer's own risk.

Information in this document is believed to be accurate and reliable. However, Dialog Semiconductor does not give any representations or warranties, express or implied, as to the accuracy or completeness of such information. Dialog Semiconductor furthermore takes no responsibility whatsoever for the content in this document if provided by any information source outside of Dialog Semiconductor.

Dialog Semiconductor reserves the right to change without notice the information published in this document, including, without limitation, the specification and the design of the related semiconductor products, software and applications. Notwithstanding the foregoing, for any automotive grade version of the device, Dialog Semiconductor reserves the right to change the information published in this document, including, without limitation, the specification and the design of the related semiconductor products, software and applications, in accordance with its standard automotive change notification process.

Applications, software, and semiconductor products described in this document are for illustrative purposes only. Dialog Semiconductor makes no representation or warranty that such applications, software and semiconductor products will be suitable for the specified use without further testing or modification. Unless otherwise agreed in writing, such testing or modification is the sole responsibility of the customer and Dialog Semiconductor excludes all liability in this respect.

Nothing in this document may be construed as a license for customer to use the Dialog Semiconductor products, software and applications referred to in this document. Such license must be separately sought by customer with Dialog Semiconductor.

All use of Dialog Semiconductor products, software and applications referred to in this document is subject to Dialog Semiconductor's [Standard Terms and Conditions of Sale](#), available on the company website ([www.dialog-semiconductor.com](http://www.dialog-semiconductor.com)) unless otherwise stated.

Dialog, Dialog Semiconductor and the Dialog logo are trademarks of Dialog Semiconductor Plc or its subsidiaries. All other product or service names and marks are the property of their respective owners.

© 2021 Dialog Semiconductor. All rights reserved.

### RoHS Compliance

Dialog Semiconductor's suppliers certify that its products are in compliance with the requirements of Directive 2011/65/EU of the European Parliament on the restriction of the use of certain hazardous substances in electrical and electronic equipment. RoHS certificates from our suppliers are available on request.

## Contacting Dialog Semiconductor

**United Kingdom (Headquarters)**  
Dialog Semiconductor (UK) LTD  
Phone: +44 1793 757700

**Germany**  
Dialog Semiconductor GmbH  
Phone: +49 7021 805-0

**The Netherlands**  
Dialog Semiconductor B.V.  
Phone: +31 73 640 8822

**Email**  
[info\\_pcbg@diasemi.com](mailto:info_pcbg@diasemi.com)

**North America**  
Dialog Semiconductor Inc.  
Phone: +1 408 845 8500

**Japan**  
Dialog Semiconductor K. K.  
Phone: +81 3 5769 5100

**Taiwan**  
Dialog Semiconductor Taiwan  
Phone: +886 281 786 222

**Web site:**  
[www.dialog-semiconductor.com](http://www.dialog-semiconductor.com)

**Hong Kong**  
Dialog Semiconductor Hong Kong  
Phone: +852 2607 4271

**Korea**  
Dialog Semiconductor Korea  
Phone: +82 2 3469 8200

**China (Shenzhen)**  
Dialog Semiconductor China  
Phone: +86 755 2981 3669

**China (Shanghai)**  
Dialog Semiconductor China  
Phone: +86 21 5424 9058