

# Application Note

## Basketball Arcade Machine

### AN-CM-234

#### Abstract

*This application note describes how to create the electronic components for a simple basketball arcade machine using a pair of Dialog GreenPAK SLG46537's.*

*This application note comes complete with design files which can be found in the References section.*

---

---

**Basketball Arcade Machine**

**Contents**

**Abstract** ..... 1

**Contents** ..... 2

**Figures**..... 2

**1 Terms and Definitions**..... 3

**2 References** ..... 3

**3 Introduction**..... 4

**4 Core Hardware**..... 4

**5 State Transitions** ..... 5

**6 Main Routine**..... 5

**7 GreenPAK Main Routine**..... 6

**8 Coin Detection** ..... 9

**9 Ticket Dispenser**..... 9

**10 Conclusion** ..... 11

**Revision History** ..... 12

**Figures**

Figure 1: System Diagram Schematic ..... 5

Figure 2. Stage 1 Section ..... 7

Figure 3. GP2Y0A60SZLF Voltage/Distance Curve ..... 7

Figure 4. Stage 2 Section ..... 8

Figure 5. Stage 3 Section ..... 8

Figure 6: The Change and Control between the UP/DOWN Functions as well as the Signals that Drive CLK ..... 10

Figure 7: The DFFs That are Used for Counter, Each One with the Necessary LUTs for Its Correct Operation ..... 10

Figure 8: Motor\_On is High When Any of the DFFs are High ..... 11

---

## Basketball Arcade Machine

### 1 Terms and Definitions

ASM	Asynchronous state machine
CMOS	Complementary mixed oxide semiconductor
LED	Light-emitting diode

### 2 References

For related documents and software, please visit:

<https://www.dialog-semiconductor.com/configurable-mixed-signal>.

Download our free [GreenPAK Designer](#) software [1] to open the .gp files [2] and view the proposed circuit design. Use the [GreenPAK development tools](#) [3] to freeze the design into your own customized IC in a matter of minutes. Dialog Semiconductor provides a complete library of application notes [4] featuring design examples as well as explanations of features and blocks within the Dialog IC.

- [1] [GreenPAK Designer Software](#), Software Download and User Guide, Dialog Semiconductor
- [2] [AN-CM-234 Basketball Arcade Machine.gp](#), [GreenPAK Design File](#), Dialog Semiconductor
- [3] [GreenPAK Development Tools](#), [GreenPAK Development Tools Webpage](#), Dialog Semiconductor
- [4] [GreenPAK Application Notes](#), [GreenPAK Application Notes Webpage](#), Dialog Semiconductor

---

## Basketball Arcade Machine

### 3 Introduction

In this application note, a pair of Dialog [GreenPAK™](#) SLG46537's is used to create the electronic components for a simple basketball arcade machine. These machines tally baskets scored within a certain amount of time. They can often be found in arcades like Chuck E. Cheese's or Dave & Buster's.

Basketball arcade machines exist in both free-to-play and pay-to-play varieties, and may or may not dispense tickets based on the number of baskets scored. We will ignore these extra options, and focus on the main elements that the machine should have.

### 4 Core Hardware

The core function of the system is sensing the ball going through the basket, so we need a proximity sensor well suited for small distances. A good pick for this job is the GP2Y0A60SZLF analog distance sensor, which has low power consumption and has been used with other [GreenPAK](#) app notes.

We are also going to need a display. Knowing that the intended use is for entertainment, and having a budget in mind, we selected two 7-segment displays of 6.5 inches in size. These parts are a couple of YSD-1100AR7B-15 units from SparkFun electronics.

The YSD-1100AR7B-15 parts need a minimum voltage of 12 V to work, so driving them directly with a GreenPAK is not a good idea. Instead, we are going to drive the displays using two CD4026 ICs, which are used for driving 7-segment LED displays with voltages up to 18 V.

We are also going to need a buzzer to emit the sounds of the game. Luckily, a simple 5 V buzzer is sufficient for this application, as most of them have decent volume.

Finally, to help the TTL signals from the [GreenPAK](#) drive the CMOS inputs of the CD4026 ICs, we need to drive the 12 V supply of the ICs.

An excellent way to shift the voltage levels is using a MOSFET and a Pull UP resistor like in the Schematic 1. (A PDF of it is included).

Basketball Arcade Machine

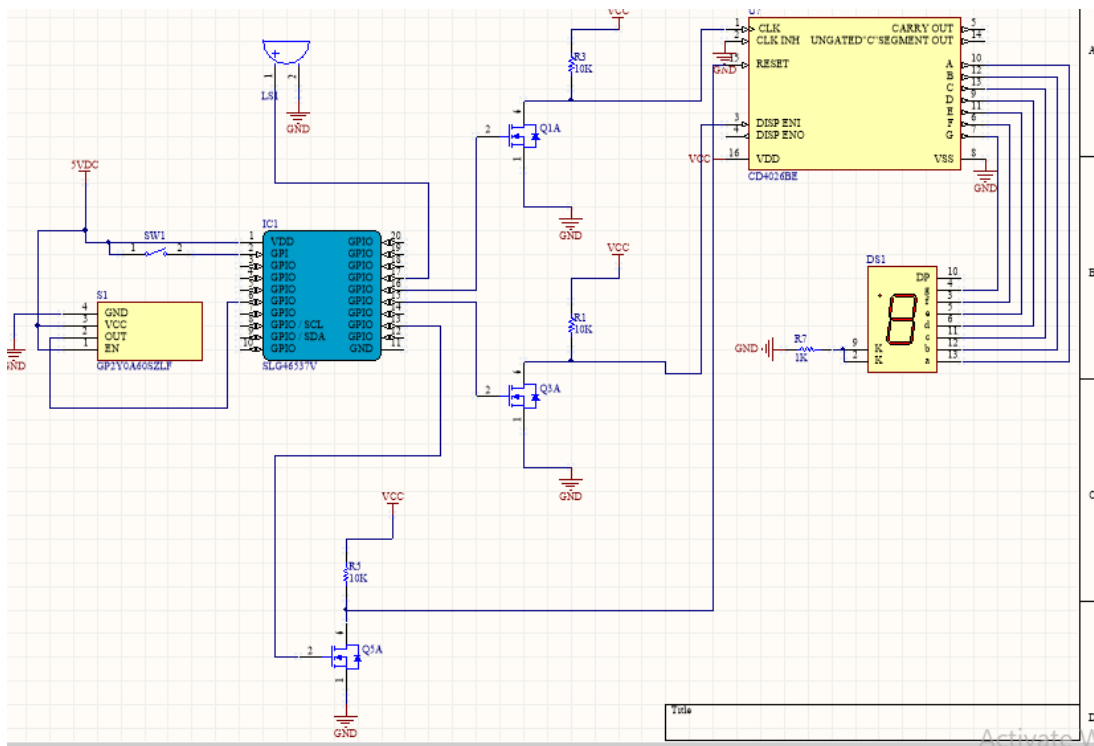

Figure 1: System Diagram Schematic

### 5 State Transitions

The arcade machine should be able to adhere to the following routine:

- State 0 - The arcade is powered on and the score display shows the last game’s score.
- State 1 - The start button is pressed, the score display is cleared, and beeping signals the start of the game.
- State 2 - This is the main game stage. It should last 60 seconds, receiving the signals that a ball has fallen inside the basket.
- State 3 - A loud beep signals game over and the score flashes before settling in a continuous fashion.
- State 0 - Repeat.

This main routine has the core functionalities of a basketball arcade machine focused on personal use.

### 6 Main Routine

In this section we are going to specify what kind of processes are going on in each of the stages.

Stage 0

The asynchronous state machine (ASM) is in state 0 waiting for the start button to be pressed, after which it will move onto stage 1.

Stage 1

## Basketball Arcade Machine

The start button was pressed and now the system is in stage 1. The system is going to emit a beep 3 times, signaling the start of the game and moving the system into stage 2. Also, it's going to reset the score shown on the display.

### Stage 2

Stage 2 is going to be activated for exactly 60 seconds. During these 60 seconds, the output of the system will be signaling a CD4026 with the quantity of times the ball passed through the basket.

### Stage 3

After the 60 seconds have passed, the system moves onto stage 3. A loud beep and the flashing lights of the display are going to signal game over, after which we reset into stage 0.

## 7 GreenPAK Main Routine

The functionality in this section relies heavily on the GreenPAK's ASM block. It only uses 4 states, but it does use all 8 of the ASM's outputs. Since the ASM has 4 unused states, we could use them to implement additional functionality. However, we will stick to the basics of the game.



Figure 1. ASM

Figure 1 shows the ASM process started with just the press of the start button.

Each one of the stages is separated in the GreenPAK design to make them easier to explain.

Stage 0 consists only of the start button, which needs no further explanation.

Stage 1 consists of a CLK divider that pulses every 512 milliseconds, which is used to generate the 3 starting beeps. It has a counter that will count 4 pulses of the CLK divider, and once it reaches the fourth pulse, it will trigger a signal to advance to Stage 2.

## Basketball Arcade Machine

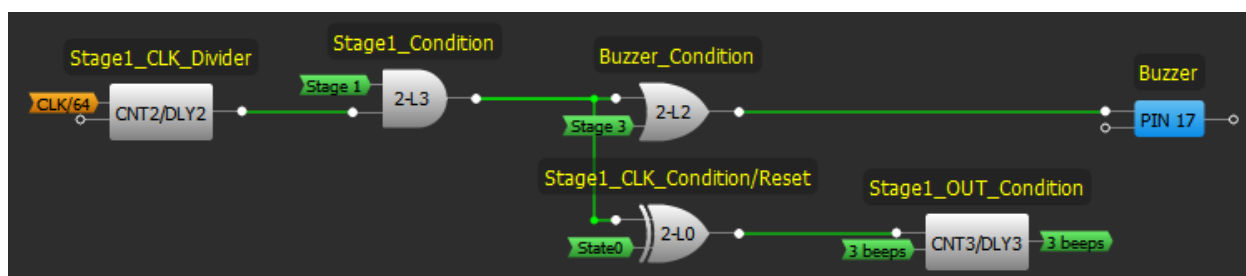

Figure 2. Stage 1 Section

This counter will maintain a HIGH on its output until it is reset. We use its output to reset itself, and the signal State 0 to provide all the conditions necessary to reset the counter and ensure the functionality of the system in further iterations of the game. Figure 2 shows Stage 1, plus the Stage 3 condition to drive the buzzer.

Stage 2 has two different components. The first is to keep track of the successful shots. At a hardware level, the ball will be detected by the GP2Y0A60SZLF proximity sensor, which will produce a certain voltage depending on the distance between itself and the ball. The GreenPAK is constantly measuring the voltage, but it will only react if two conditions are met: the GreenPAK detects a voltage greater than 4 V (selected using the GP2Y0A60SZLF table shown in Figure 3) and the system is in Stage 2.

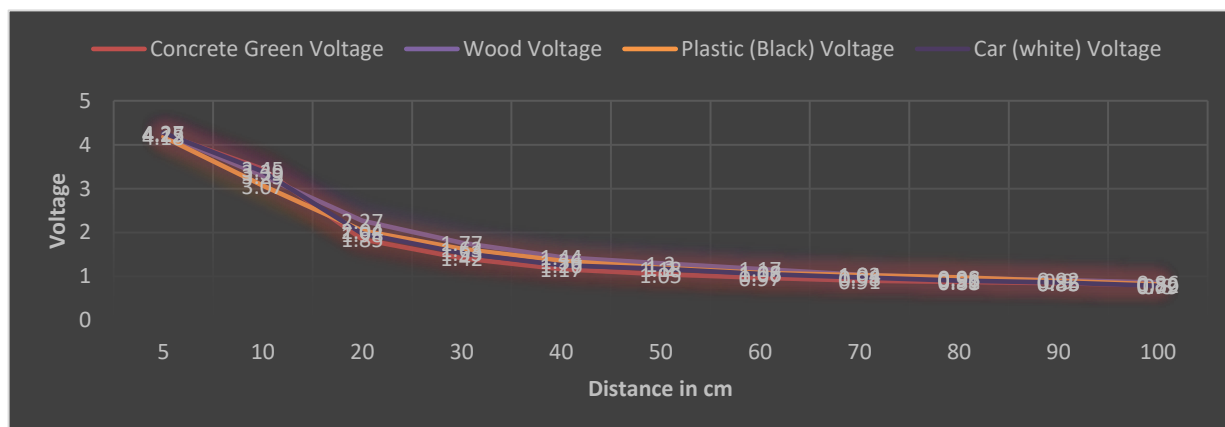

Figure 3. GP2Y0A60SZLF Voltage/Distance Curve

The second component of Stage 2 is to keep track of the 60 seconds in which the game is played. To do that we use a pair of counters and a LUT to create a 60 s timer. Figure 4 features both these processes and a very similar reset condition as the one presented in Stage 1.

Basketball Arcade Machine

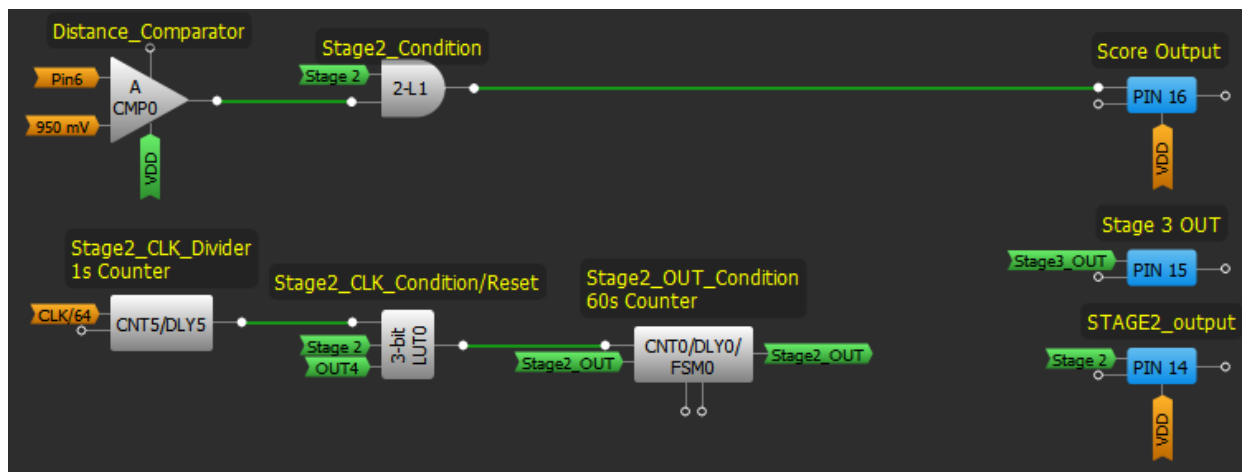

Figure 4. Stage 2 Section

Stage 3 should emit a long beep and blink the display five times. To do this we again need to use a CLK divider. We configure it to pulse every 200 milliseconds and count 5 pulses. As the display is always HIGH during the game, we use an XOR block to make it blink. The condition of the long beep is visible in Figure 2, and the conditions of stage 3 are shown in Figure 5.

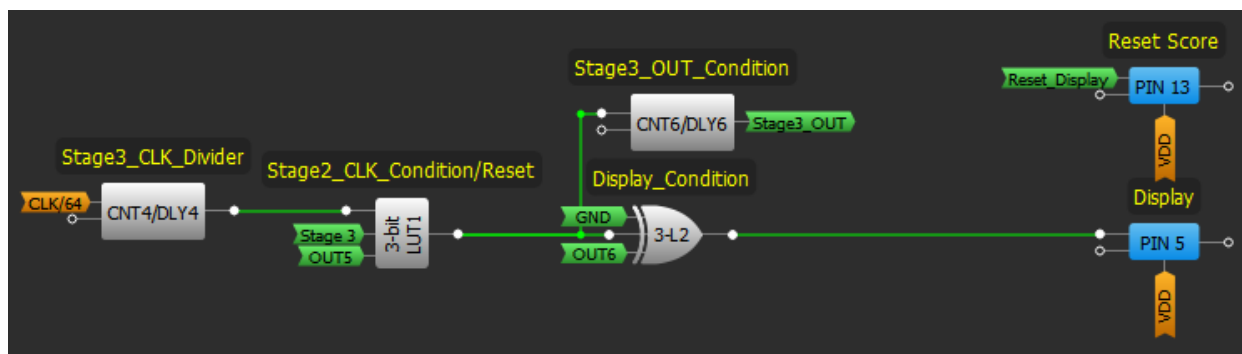

Figure 5. Stage 3 Section

So far, the budget for the electronic parts of the system is \$47.50 USD (plus shipping expenses). The overall budget will change depending on the materials of construction (wood, steel, glass fiber, etc.), but in general terms the electronic parts are going to cost pretty much the same (unless we mass produce which would certainly reduce the manufacturing price per unit).

To get a clearer picture, a device with similar characteristics but featuring 2 players can be found at a price of \$360.00 USD plus shipping. Implementing a second player on our system would cost an additional \$47.50 USD. Adding on \$50.00 USD for the structure of the arcade machine would give us a price tag of \$145.00 USD plus shipping. Again, this manufacturing price will go down depending on the production scale.

This concludes the main objective of this app note. But if the intended use of this machine is as a for-profit arcade machine, the following designs may help with that implementation. Please note that all these solutions rely on more hardware and an additional GreenPAK.



---

## Basketball Arcade Machine

### 8 Coin Detection

Solutions can be classified as hardware solutions or software solutions, or a mixture of both. The easiest way to implement coin detection would be to use sorting hardware and a simple software implementation.

The hardware solution is a rail with a gap big enough to make rejected coins fall, but small enough to let the accepted coins pass. An infrared LED emitter and receiver will signal that a coin has passed.

This solution is simple enough to be implemented as an additional stage in the main routine, or even using a LATCH block.

Using the LATCH means the HIGH value of the coin detector is going to be HIGH until we reset the LATCH using a reset condition, which will be Start\_Button AND Token\_Memory being HIGH at the same time.

### 9 Ticket Dispenser

For this we are going to use a second GreenPAK, and using the score output signal we are going to create a condition.

First, we have to define two signals: SCORE\_UP and TICKET\_OUT.

The first signal will go through a frequency divider, so every two points the CLK is going to finish one cycle.

The second signal is going to count one cycle with every pulse.

We also have a 3 bit UP/DOWN counter that we are going to use to monitor the number of tickets we are going to give away. This design is able to give away a maximum of 7 tickets, if the player scores 14 points in the sixty seconds of the game.

Once stage 2 is over, a motor is turned on as long as any of the 3 bits is HIGH. That counter is going to decrease once a ticket is sensed by the TICKET\_OUT signal.

The stages of this design can be observed in [Figure 6](#), [Figure 7](#), and [Figure 8](#).



## Basketball Arcade Machine

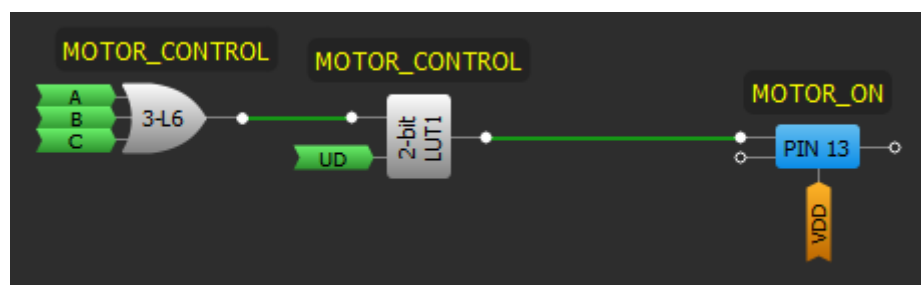

**Figure 8: Motor\_On is High When Any of the DFFs are High**

It can only be turned on when the UD signal is LOW, which signals the counter should be going down.

The design of this ticket dispenser is simple but very useful. Since the truth table was designed to avoid overflow, the maximum stays at 7, even when the player scores more than 14 shots.

## 10 Conclusion

Using a Dialog [GreenPAK](#) SLG46537, we were able to successfully implement a homemade Basketball Arcade Machine which counts baskets and displays the score on 7-segment LEDs. It can also dispense tickets to the user. Thanks to [GreenPAK](#) and its GreenPAK Designer Software, this project was easy and affordable to implement.

---

**Basketball Arcade Machine**

**Revision History**

<b>Revision</b>	<b>Date</b>	<b>Description</b>
1.0	14-Mar-2018	Initial Version

## Basketball Arcade Machine

### Status Definitions

Status	Definition
DRAFT	The content of this document is under review and subject to formal approval, which may result in modifications or additions.
APPROVED or unmarked	The content of this document has been approved for publication.

### Disclaimer

Information in this document is believed to be accurate and reliable. However, Dialog Semiconductor does not give any representations or warranties, expressed or implied, as to the accuracy or completeness of such information. Dialog Semiconductor furthermore takes no responsibility whatsoever for the content in this document if provided by any information source outside of Dialog Semiconductor.

Dialog Semiconductor reserves the right to change without notice the information published in this document, including without limitation the specification and the design of the related semiconductor products, software and applications.

Applications, software, and semiconductor products described in this document are for illustrative purposes only. Dialog Semiconductor makes no representation or warranty that such applications, software and semiconductor products will be suitable for the specified use without further testing or modification. Unless otherwise agreed in writing, such testing or modification is the sole responsibility of the customer and Dialog Semiconductor excludes all liability in this respect.

Customer notes that nothing in this document may be construed as a license for customer to use the Dialog Semiconductor products, software and applications referred to in this document. Such license must be separately sought by customer with Dialog Semiconductor.

All use of Dialog Semiconductor products, software and applications referred to in this document are subject to Dialog Semiconductor's [Standard Terms and Conditions of Sale](http://www.dialog-semiconductor.com), available on the company website ([www.dialog-semiconductor.com](http://www.dialog-semiconductor.com)) unless otherwise stated.

Dialog and the Dialog logo are trademarks of Dialog Semiconductor plc or its subsidiaries. All other product or service names are the property of their respective owners.

© 2018 Dialog Semiconductor. All rights reserved.

## Contacting Dialog Semiconductor

### United Kingdom (Headquarters)

*Dialog Semiconductor (UK) LTD*  
Phone: +44 1793 757700

### Germany

*Dialog Semiconductor GmbH*  
Phone: +49 7021 805-0

### The Netherlands

*Dialog Semiconductor B.V.*  
Phone: +31 73 640 8822

### Email:

[enquiry@diasemi.com](mailto:enquiry@diasemi.com)

### North America

*Dialog Semiconductor Inc.*  
Phone: +1 408 845 8500

### Japan

*Dialog Semiconductor K. K.*  
Phone: +81 3 5769 5100

### Taiwan

*Dialog Semiconductor Taiwan*  
Phone: +886 281 786 222

### Web site:

[www.dialog-semiconductor.com](http://www.dialog-semiconductor.com)

### Hong Kong

*Dialog Semiconductor Hong Kong*  
Phone: +852 2607 4271

### Korea

*Dialog Semiconductor Korea*  
Phone: +82 2 3469 8200

### China (Shenzhen)

*Dialog Semiconductor China*  
Phone: +86 755 2981 3669

### China (Shanghai)

*Dialog Semiconductor China*  
Phone: +86 21 5424 9058