

Application Note

Analog Clock Motor Driver

AN-CM-241

Abstract

This application note describes how to implement all the active electronic functions needed in an analog clock, including motor driver and crystal oscillator using a Dialog GreenPAK IC. This application note comes complete with design files which can be found in the References section.

Contents

Abstract 1

Contents 2

Figures..... 2

1 Terms and Definitions..... 3

2 References 3

3 Introduction..... 4

4 Background: Lavet Type Stepper Motors..... 4

5 Motor Driver 4

6 Crystal Oscillator..... 5

7 Results..... 6

8 Conclusion 6

Revision History 7

Figures

Figure 1: Lavet Type Stepper Motor Rotation Pattern (En.wikipedia.org, 2018) 4

Figure 2: Circuit Diagram of Internal Connections 5

Figure 3: Circuit Diagram of External Connections 5

Figure 4: Motor Driver Output Waveform, 10 ms on, 990 ms off 6

Analog Clock Motor Driver

1 Terms and Definitions

| | |
|------|-----------------------------------|
| CMIC | Configurable mixed-signal circuit |
| IC | Integrated circuit |

2 References

For related documents and software, please visit:

<https://www.dialog-semiconductor.com/configurable-mixed-signal>.

Download our free [GreenPAK Designer](#) software [1] to open the .gp files [2] and view the proposed circuit design. Use the [GreenPAK development tools](#) [3] to freeze the design into your own customized IC in a matter of minutes. Dialog Semiconductor provides a complete library of application notes [4] featuring design examples as well as explanations of features and blocks within the Dialog IC.

- [1] [GreenPAK Designer Software](#), Software Download and User Guide, Dialog Semiconductor
- [2] [AN-CM-241 Analog Clock Motor Driver.gp](#), [GreenPAK Design File](#), Dialog Semiconductor
- [3] [GreenPAK Development Tools](#), [GreenPAK Development Tools Webpage](#), Dialog Semiconductor
- [4] [GreenPAK Application Notes](#), [GreenPAK Application Notes Webpage](#), Dialog Semiconductor
- [5] Lavet-type stepping motor, En.wikipedia.org, (2018)

Analog Clock Motor Driver

3 Introduction

Even in a digital world, classic analog clocks have a timeless style that is here to stay. We can use a dual-rail **GreenPAK™** CMIC to implement all the active electronic functions needed in an analog clock, including motor driver and crystal oscillator. **GreenPAKs** are low-cost, tiny devices that fit right in with smart watches. As an easy-to-build demonstration, I obtained a cheap wall clock, removed the existing board, and replaced all the active electronics with one **GreenPAK** device.

4 Background: Lavet Type Stepper Motors

A typical analog clock uses a Lavet type stepper motor to turn the pinion gear of the clock mechanism. It is a single-phase motor that consists of a flat stator (stationary part of the motor) with an inductive coil wrapped around an arm. Between the arms of the stator lies the rotor (moving part of the motor) which consists of a circular permanent magnet with a pinion gear attached to the top of it. The pinion gear coupled with other gears move the clock hands.

The motor works by alternating the polarity of current in the stator coil with a pause between the polarity changes. During current pulses, the induced magnetism pulls the motor to align the poles of the rotor and stator. While the current is off, the motor is pulled to one of two other positions by reluctant force. These reluctance rest positions are engineered by the design of non-uniformities (notches) in the metal motor housing so that the motor rotates in one direction (see [Figure 1](#)).

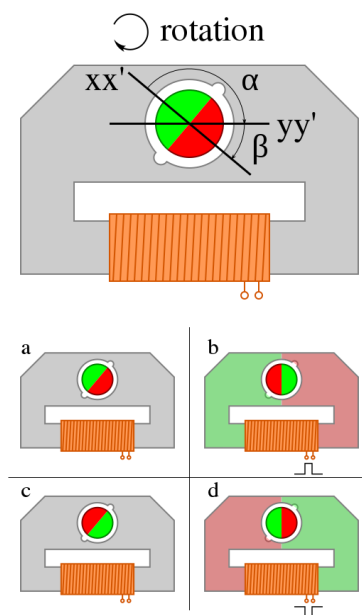

Figure 1: Lavet Type Stepper Motor Rotation Pattern ([En.wikipedia.org](https://en.wikipedia.org), 2018)

5 Motor Driver

The attached design uses a SLG46121V to produce the required current waveforms through the stator coil. Separate 2x push-pull outputs on the IC (labeled M_1 and M_2) connect to each end of the coil, and drive the alternating pulses. It is necessary to use push-pull outputs for this device to operate correctly.

The waveform consists of a 10 ms pulse each second, alternating between M_1 and M_2 with each pulse. The pulses are created with just a few blocks driven from a simple 32.768 kHz crystal oscillator circuit. The OSC block conveniently has built in dividers to help divide down the 32.768 kHz clock. CNT1 outputs a clock pulse every second. This pulse triggers a 10 ms one-shot circuit. Two LUTs (labeled 1 and 2) demultiplex the 10 ms pulse to the output pins. Pulses are passed to M_1 when DFF5 output is high, M_2 when low.

Analog Clock Motor Driver

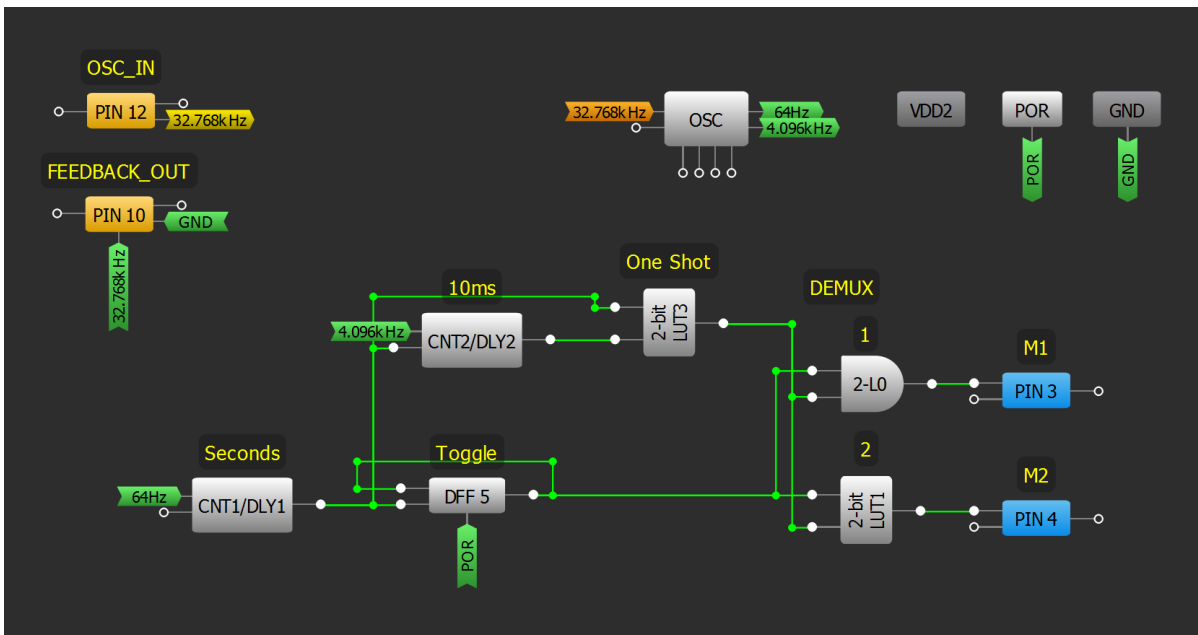

Figure 2: Circuit Diagram of Internal Connections

6 Crystal Oscillator

The 32.768 kHz crystal oscillator uses just two pin blocks on the chip. PIN12 (OSC_IN) is set as a low-voltage digital input (LVDI), which has relatively low switching current. The signal from PIN12 feeds into the OE of PIN10 (FEEDBACK_OUT). PIN10 is configured as a 3-state output with input wired to ground, making it act like an open drain NMOS output. This signal path naturally inverts, so no other block is needed. Externally, the PIN 10 output is pulled up to VDD2 (PIN11) by a 1MΩ resistor (R4). Both PIN10 and PIN12 are powered by the VDD2 rail, which in-turn is current limited 1 MΩ resistor to VDD. R1 is a feedback resistor to bias the inverting circuit, and R2 limits output drive. Adding the crystal and capacitors completes the Pierce oscillator circuit as shown in Figure 3.

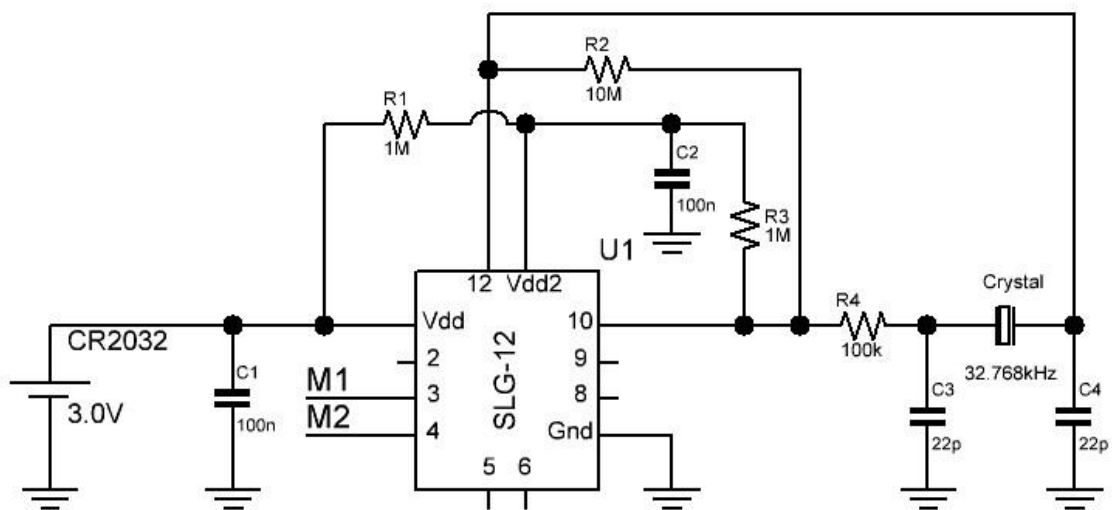

Figure 3: Circuit Diagram of External Connections

7 Results

VDD was powered by a CR2032 lithium coin battery which typically provides 3.0 V (3.3 V when fresh). The output waveform consists of alternating 10 ms pulses as shown below in [Figure 4](#). Averaged over a minute, the measured current draw was roughly 97 μ A including the motor drive. Without the motor, the current draw was 2.25 μ A.

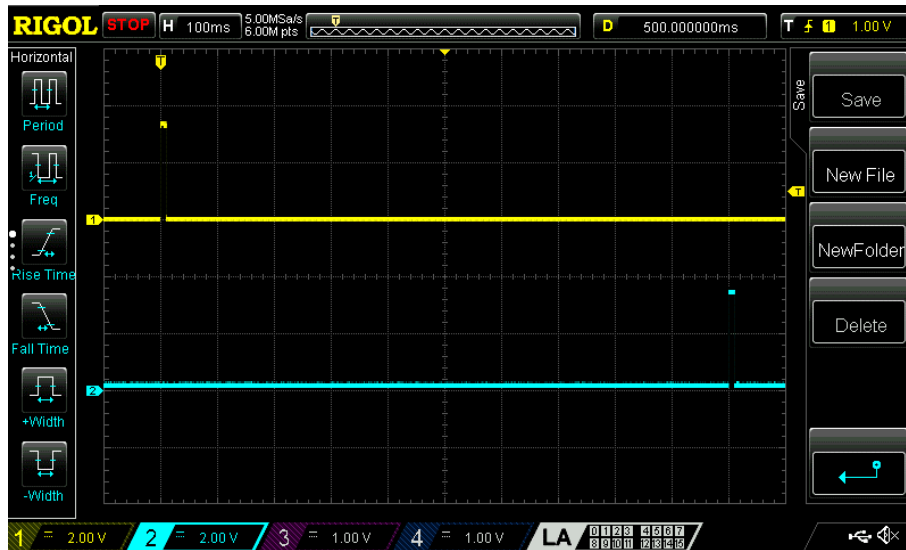

Figure 4: Motor Driver Output Waveform, 10 ms on, 990 ms off

8 Conclusion

This application note provides a [GreenPAK](#) demonstration of a complete solution for driving an analog clock stepper motor and can be the basis for other more specialized solutions. This solution only uses a portion of the [GreenPAK](#) resources, which leaves the IC open to additional functions left only to your imagination.

Revision History

| Revision | Date | Description |
|----------|-------------|-----------------|
| 1.0 | 17-Apr-2018 | Initial Version |

Analog Clock Motor Driver

Status Definitions

| Status | Definition |
|-------------------------|--|
| DRAFT | The content of this document is under review and subject to formal approval, which may result in modifications or additions. |
| APPROVED or unmarked | The content of this document has been approved for publication. |

Disclaimer

Information in this document is believed to be accurate and reliable. However, Dialog Semiconductor does not give any representations or warranties, expressed or implied, as to the accuracy or completeness of such information. Dialog Semiconductor furthermore takes no responsibility whatsoever for the content in this document if provided by any information source outside of Dialog Semiconductor.

Dialog Semiconductor reserves the right to change without notice the information published in this document, including without limitation the specification and the design of the related semiconductor products, software and applications.

Applications, software, and semiconductor products described in this document are for illustrative purposes only. Dialog Semiconductor makes no representation or warranty that such applications, software and semiconductor products will be suitable for the specified use without further testing or modification. Unless otherwise agreed in writing, such testing or modification is the sole responsibility of the customer and Dialog Semiconductor excludes all liability in this respect.

Customer notes that nothing in this document may be construed as a license for customer to use the Dialog Semiconductor products, software and applications referred to in this document. Such license must be separately sought by customer with Dialog Semiconductor.

All use of Dialog Semiconductor products, software and applications referred to in this document are subject to Dialog Semiconductor's [Standard Terms and Conditions of Sale](http://www.dialog-semiconductor.com), available on the company website (www.dialog-semiconductor.com) unless otherwise stated.

Dialog and the Dialog logo are trademarks of Dialog Semiconductor plc or its subsidiaries. All other product or service names are the property of their respective owners.

© 2018 Dialog Semiconductor. All rights reserved.

Contacting Dialog Semiconductor

United Kingdom (Headquarters)

Dialog Semiconductor (UK) LTD
Phone: +44 1793 757700

Germany

Dialog Semiconductor GmbH
Phone: +49 7021 805-0

The Netherlands

Dialog Semiconductor B.V.
Phone: +31 73 640 8822

Email:

enquiry@diasemi.com

North America

Dialog Semiconductor Inc.
Phone: +1 408 845 8500

Japan

Dialog Semiconductor K. K.
Phone: +81 3 5769 5100

Taiwan

Dialog Semiconductor Taiwan
Phone: +886 281 786 222

Web site:

www.dialog-semiconductor.com

Hong Kong

Dialog Semiconductor Hong Kong
Phone: +852 2607 4271

Korea

Dialog Semiconductor Korea
Phone: +82 2 3469 8200

China (Shenzhen)

Dialog Semiconductor China
Phone: +86 755 2981 3669

China (Shanghai)

Dialog Semiconductor China
Phone: +86 21 5424 9058