

Application Note

Battery Powered Overdrive Pedal for Guitar Effects

AN-CM-279

Abstract

This application note covers the creation of a low voltage low power overdrive pedal using a Dialog GreenPAK SLG88104V.

This application note includes a circuit diagram using 3V i.e. two AA batteries, a thorough explanation, diagrams, overview, graph and picture.

EVB versions of GreenPAK operational amplifiers are ready manufactured breakout boards with the operational amplifier on board and soldered. These make it very easy to test designs using through hole methods.

Battery Powered Overdrive Pedal for Guitar Effects

Contents

Abstract	1
Contents	2
Figures	2
1 Terms and Definitions	3
2 References	3
3 Introduction	4
4 Prerequisites	5
4.1 Overview	5
4.2 Explanation and Theory	6
5 Circuit Diagram	9
5.1 Circuit Explained	10
6 Conclusions	11
Revision History	12

Figures

Figure 1: Strong Square Wave Like Clipping, Indicative Example	4
Figure 2: Overview Block Diagram of Overdrive Circuit	5
Figure 3: Non-inverting Amplifier Topology	6
Figure 4: Non-inverting Amplifier Topology Incorporating Frequency Selective Gain – Dual Version ..	7
Figure 5: Graph Demonstrating Hypothetical Frequency Selective Amplification Gain	8
Figure 6: Low Voltage, Low Power Overdrive – Circuit Diagram	9
Figure 7: Picture of Prototype as per Circuit Diagram using the SLG88104V-EVB	11
Figure 8: 500Hz Scope Display	11
Figure 9: 1kHz Scope Display	11

Battery Powered Overdrive Pedal for Guitar Effects

1 Terms and Definitions

Buffer	An amplifier, usually with unity gain, that serves as a protective barrier to preserve current sink/source capabilities
Clipping	A type of wave distortion that occurs when a signal is amplified to the extent such that the wave “clips” or hits the rail lines
Div	Divide
OpAmp	Operational amplifier
Scope	Oscilloscope

2 References

For related documents and software, please visit:

<https://www.dialog-semiconductor.com/configurable-mixed-signal>.

Download our free [GreenPAK™](#) Designer software [1] and use the [GreenPAK](#) development tools [2] to freeze the design into your own customized IC in a matter of minutes. Dialog Semiconductor provides a complete library of application notes [3] featuring design examples as well as explanations of features and blocks within the Dialog IC.

- [1] [GreenPAK Designer Software](#), Software Download and User Guide, Dialog Semiconductor
- [2] [GreenPAK Development Tools](#), [GreenPAK Development Tools Webpage](#), Dialog Semiconductor
- [3] [GreenPAK Application Notes](#), [GreenPAK Application Notes Webpage](#), Dialog Semiconductor
- [4] [SLG88104V](#) Datasheet, Dialog Semiconductor
- [5] [SLG88104V-EVB](#) See [SLG88104V Datasheet](#), Dialog Semiconductor.

Battery Powered Overdrive Pedal for Guitar Effects

3 Introduction

For the love of music or for the love of electronics, the aim of this application note is to show how critical the SLG88104V Rail to Rail I/O 375nA Quad OpAmp with its low power and low voltage advancements can be to revolutionize overdrive circuits.

Typical overdrive designs on the market today run at 9V. However, as explained here we have been able to achieve an overdrive that is extremely economical in its power usage and running on such a low VDD that it can work using only two AA batteries at three volts for extended periods and extremely long battery life. To further preserve batteries left in the unit, a mechanical switch for disengagement is used as standard. In addition, as the footprint of the SLG88104V is small with minimal amount of batteries used, a small light weight pedal can be made if desired. All of this combined with likeable sound effects makes it a leading overdrive design.

Amplified guitars appeared in the early 1930's. However, at that time early recording artists strove for clean orchestra type sounds. By the 40's DeArmond manufactured the world's first standalone effect. But at that time amplifiers were valve based and bulky. During the 40's and through to the 50's even though clean tones were prevalent, competitive individuals and bands frequently turned their amps volume up to overdrive status and the distortion sound became increasingly popular. In the 60's transistor amplifiers started to be manufactured with the Vox T-60, in 1964 and around the same era to further preserve the distortion sound which was very sought after at that time the first distortion effect was born.

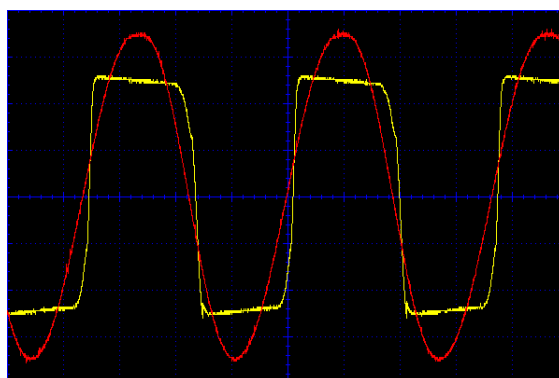

Figure 1: Strong Square Wave Like Clipping, Indicative Example

Battery Powered Overdrive Pedal for Guitar Effects

4 Prerequisites

Analog or digital processing of music signals can provide new effects, and active overdrive effects recreate the overdriven clipping effects of those early valve amps.

Usually unwanted and minimized in terms of amplification the opposite is true in terms of this effect. Clipping produces frequencies that are not present in the original sound and that could have been partly the reason for its appeal in the early days. Strong and almost square wave related clipping produces very harsh sounds that are inharmonic to its parent tone, while soft clipping produces harmonic overtones and so generally the sound produced depends on the amount of clipping and depletion with frequency. It's the strong belief of this author that the quality of an overdrive pedal depends on its proportion of harmonic to inharmonic tones throughout its range and its ability to preserve the harmonic tones at higher amplifications.

4.1 Overview

Below is an overview of a proposed circuit, the aim of which is to preserve existing signals and produce those overdrive sounds. Using the SLG88104V allows an Overdrive pedal running on 3 V using two AA batteries which are much more widely available and less expensive to purchase than 9 V PP3 batteries. If desired, AAA batteries can be used instead, although the extra capacity of the AA make it more than apt. Further, the circuit will be able to work on 4.5 V (1.5 V center line +3 V) or 6 V (3 V center line +3 V) if desired, although not necessary.

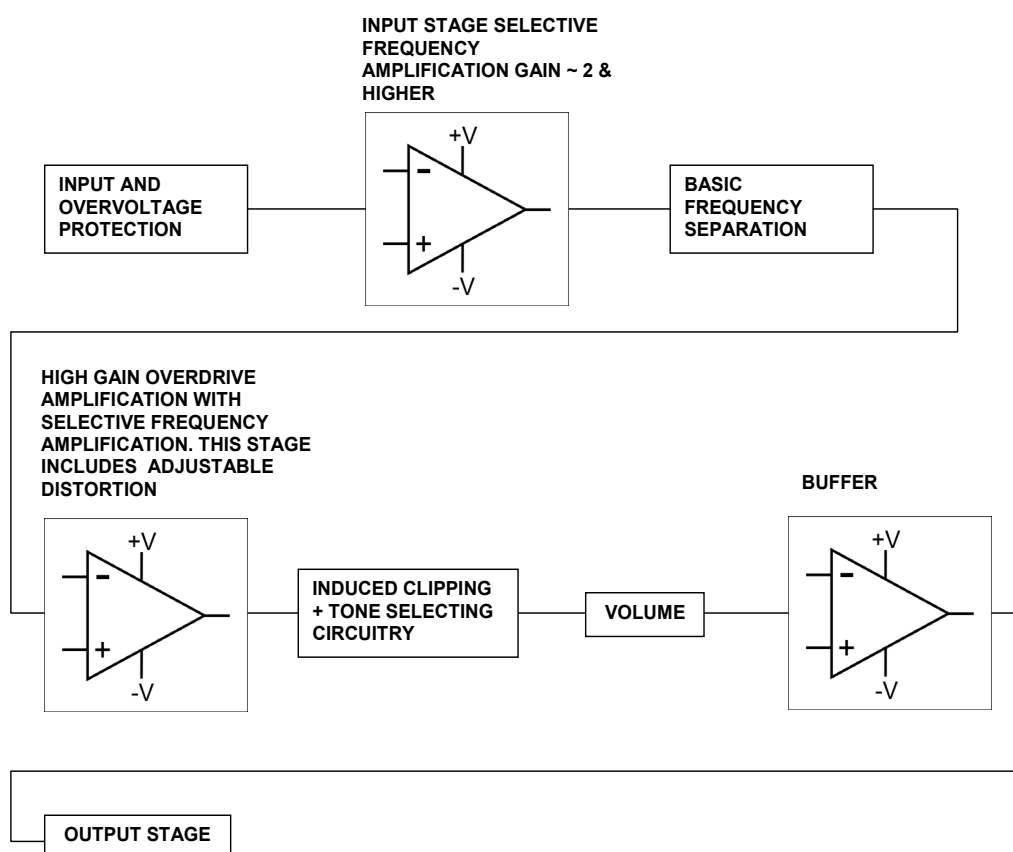

Figure 2: Overview Block Diagram of Overdrive Circuit

Selective frequency amplification - important modification to accomplish amplification at lower voltages.

Battery Powered Overdrive Pedal for Guitar Effects

4.2 Explanation and Theory

We choose to use the non-inverting topology of the amplifier as a base for the gain stages due to its high input impedance and easy adaption for frequency selection.

$$AGain = 1 + \frac{R2}{R1}$$

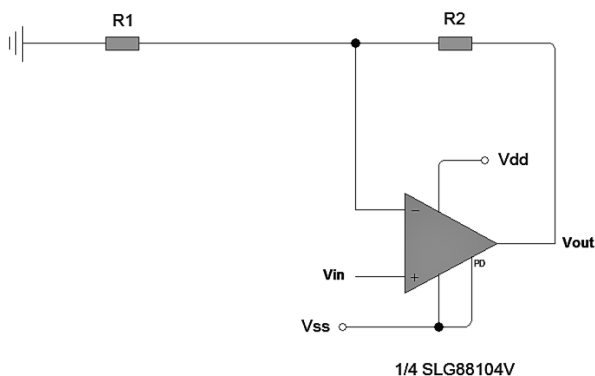

Figure 3: Non-inverting Amplifier Topology

As we have seen, the gain in this set up is solely conditional on the feedback. If we convert this as a high pass topology, gain will be dependent on feedback and input frequencies as per some overdrive arrangements. Further, if the filter feedback circuitry is doubled, then the topology will apply one range of responsive gains to the input and then a further different set of responsive gains.

This setup can serve to both clarify the design and allow a more frequency directional / selective amplification. Below is the diagram of such arrangement with formulas producing interesting conclusions. This topology is an important crux relied upon by the final overdrive circuitry which will incorporate it as a main core several times to maintain a working model.

If we look at things a little simpler, then for a certain frequency f

$$AGain = 1 + \frac{2\pi f C1 R2}{2\pi f C1 R1 + 1}$$

and

$$AGain = 1 + \frac{2\pi f C1 R2}{2\pi f C2 R3 + 1}$$

Battery Powered Overdrive Pedal for Guitar Effects

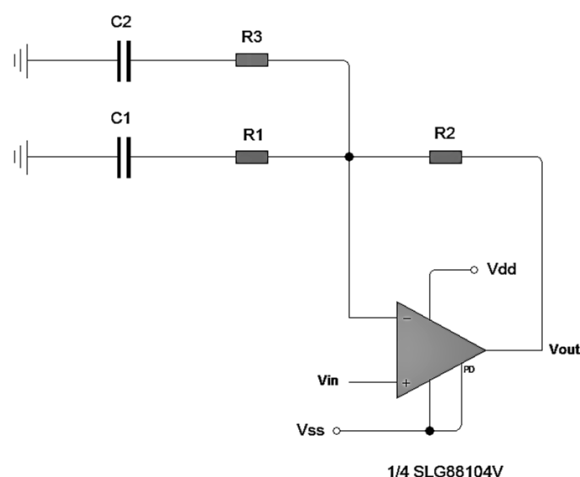

Figure 4: Non-inverting Amplifier Topology Incorporating Frequency Selective Gain – Dual Version

The actual equation for AGain at a particular frequency f is thus:

$$AGain = 1 + \frac{R1R2 + R3R2 + \left(\frac{R2}{2\pi f C1}\right) + \left(\frac{R2}{2\pi f C2}\right)}{\left(R1 + \frac{1}{2\pi f C1}\right) \left(R3 + \left(\frac{1}{2\pi f C2}\right)\right)}$$

which breaks down further to produce a final formula:

$$AGain = 1 + \frac{2\pi f C1 R1}{2\pi f C1 R1 + 1} + \frac{2\pi f C2 R2}{2\pi f C2 R3 + 1}$$

As evident this is analogous to the addition of the simplified equations above except for the inherent unity gain of the amplifier which is constant. In summary the frequency response gain of each high pass feedback topology leg is compounded.

The aim of such arrangements is to obtain a more uniform amplification of the input signal over the frequency range so that at higher frequencies where the OpAmp's gain is reduced, we can introduce more gain. At low voltages the sound can be preserved through those low frequencies even though the headroom is not very high.

Battery Powered Overdrive Pedal for Guitar Effects

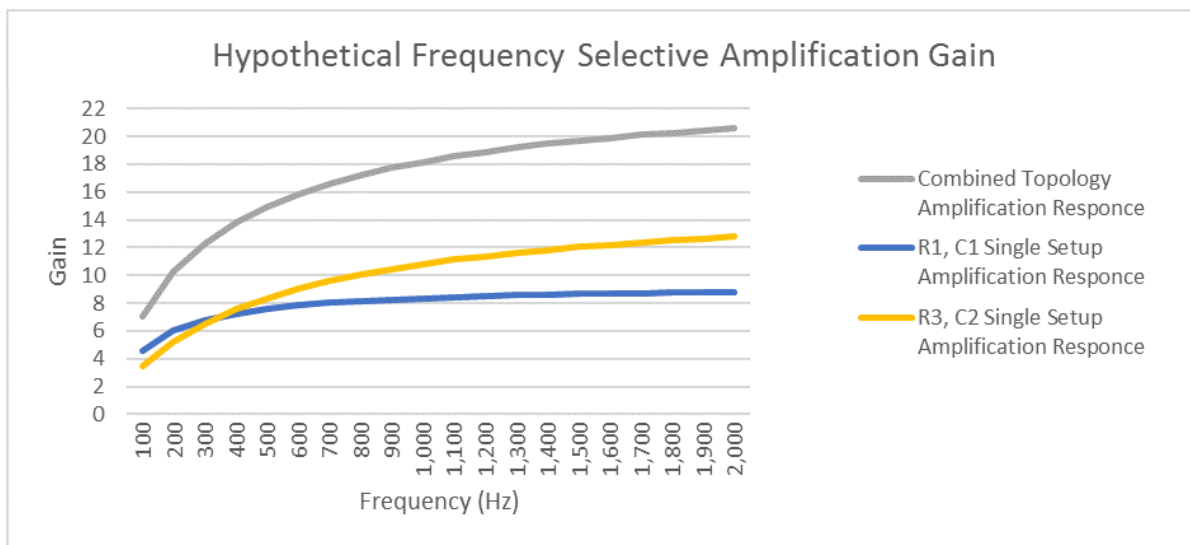

Figure 5: Graph Demonstrating Hypothetical Frequency Selective Amplification Gain

Battery Powered Overdrive Pedal for Guitar Effects

5 Circuit Diagram

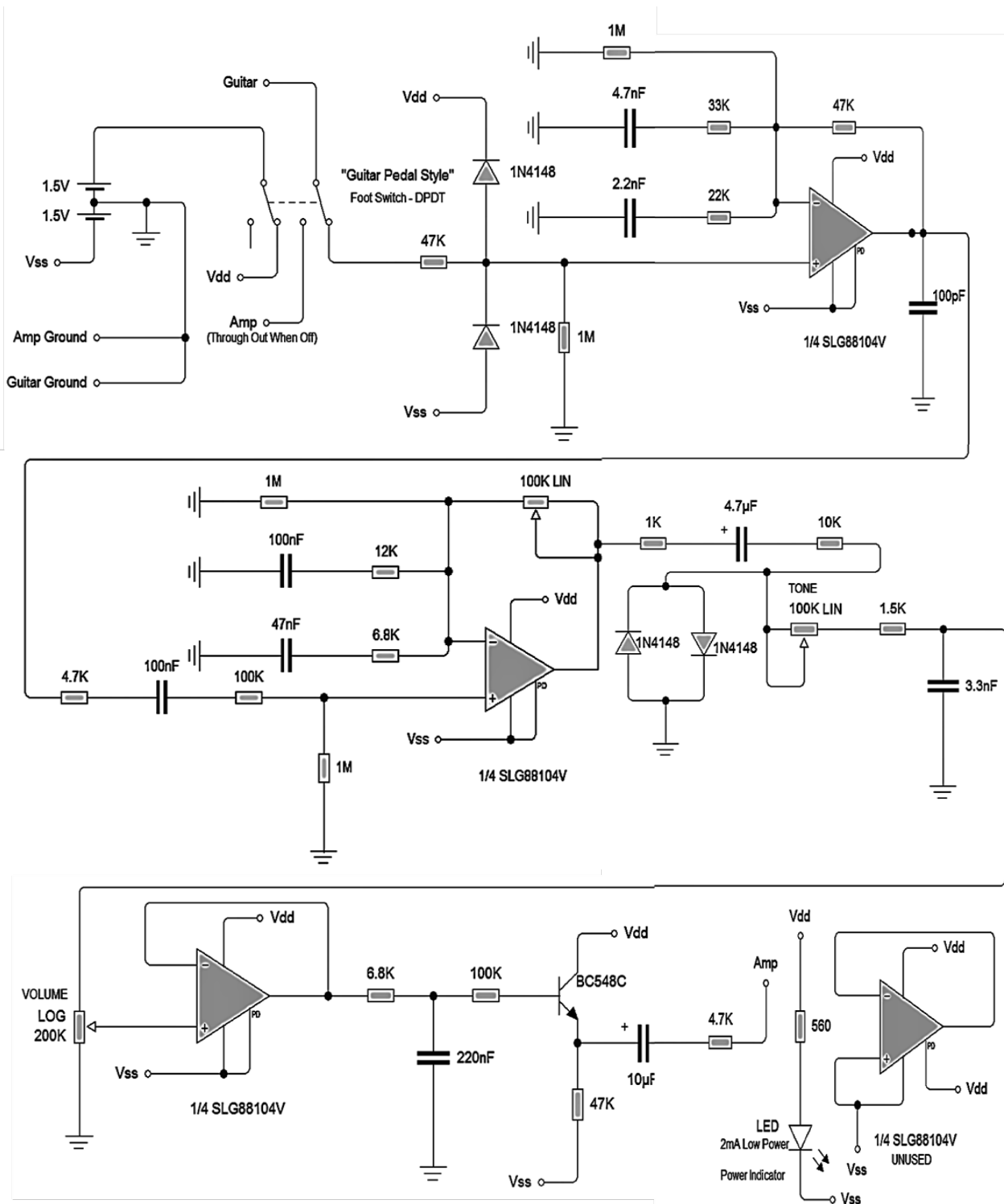

Figure 6: Low Voltage, Low Power Overdrive – Circuit Diagram

Battery Powered Overdrive Pedal for Guitar Effects

5.1 Circuit Explained

The SLG88103/4V incorporates innate input protection to prevent overvoltage at its inputs. Extra protection diodes have been added at the initial stage of overdrive input for extra design robustness.

First stage amplification acts as a first stage high impedance buffer and amplifies initially to prepare for the overdrive stage. Gain is around two although it varies with frequency. At this stage care needs to be taken to ensure that the amplification stays low, as any amplification at this stage is multiplied into the overdrive amplification.

Following through to the overdrive stage, where the signal will undergo large gains, frequency selective amplification again ensures that the higher frequencies get that boost for a more consistent amplification, and consecutively we induce clipping using two diodes in forward conductive mode. A simple low pass filter forms the tone, and this leads to a simple volume potentiometer and a buffer to drive the output.

Only three of the on-board Operational Amplifiers are utilized, and the last remaining one is wired appropriately as per “proper setup for unused OpAmps”. If desired, 2 x SLG88103V’S can be used instead of the single SLG88104V.

A low power light emitting diode indicates an on-state. The importance of it being a low power version cannot be understated due to the low quiescent currents and running power of the SLG88104V. The main power consumption from the circuit will be the power indicator LED.

In fact, due to the extremely low 375 nA quiescent current, the power consideration for the **GreenPAK** SLG88104V is very small. The majority of power loss is through the decoupling low pass capacitors and the emitter follower resistor. If we measure the current consumption of the complete circuit’s quiescent current, it turns out to be only about 20 μ A, increasing to around a maximum of 90 μ A when the guitar is in action. This is very small compared to the 2 mA consumed by the LED and is the reason that the use of a low power LED is imperative. We can estimate the average life of a single AA alkaline battery to drain from full to 1 V is around 2000 mAh* at a discharge rate of 100 mA. A decent new pair of batteries producing 3 V should then be able to source over 4000 mAh. With the LED in place our circuit measures a 1.75 mA draw from which we can estimate over 2285 hours or 95 days of continuous usage. Because overdrives are active circuits our overdrive can produce “a hell of a kick” at minimal current usage. As a side note, two AAA batteries should last around half the time of the AA.

Below is the working model of this overdrive circuit. Obviously, as with any pedal, the user needs to adjust the settings to find the sound that is most apt for them. Turning the amp’s mid and bass higher than treble seemed to give really cool overdrive sounds for us (as treble was harsher). It then resembled the warmer old-fashioned type of sound.

Because of the **GreenPAK** SLG88104V’s tiny package and very low power consumption, we have succeeded in achieving a low power overdrive pedal that is less bulky and runs on only two pencil type batteries for a great length of time.

AA batteries are more readily available, and there is the possibility that they will not be changed for the life of any working unit, making it extremely easy maintenance and ecologically friendly. Further, it can be built with a small number of external components, so it can be low cost, easy to make, and as stated previously, lightweight.

* Source: Energizer E91 Datasheet (see bar graph), powerstream.com

Battery Powered Overdrive Pedal for Guitar Effects

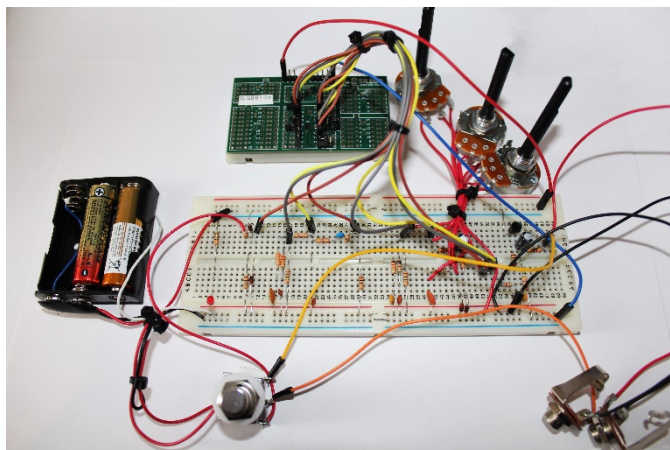

Figure 7: Picture of Prototype as per Circuit Diagram using the SLG88104V-EVB

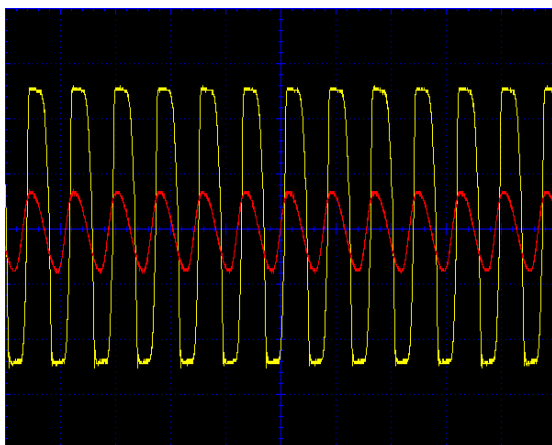

Figure 8: 500Hz Scope Display

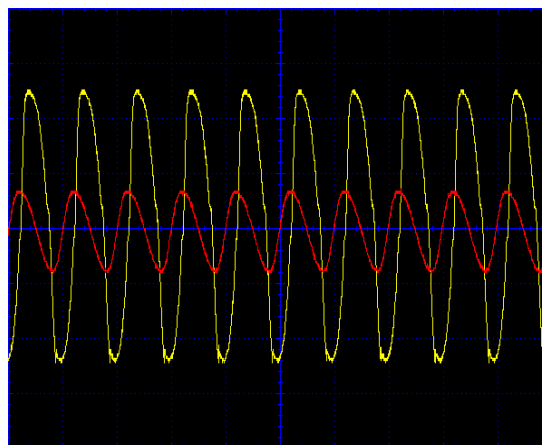

Figure 9: 1kHz Scope Display

Figure 8: Ch1 Red, Ch2 Yellow. Ch1 Overdrive Input, Sine Wave, 304 Vpk-pk, 513 Hz. 200 mV/Div, Timebase 2.5 mS. Ch2 Overdrive Buffer Output, Clipped Sine Wave, 1.024 Vpk-pk 513 Hz. 200 mV/Div, Timebase 2.5 mS

Figure 9: Ch1 Red, Ch2 Yellow. Ch1 Overdrive Input, Sine Wave, 304 Vpk-pk, 1 kHz. 200 mV/Div, Timebase 1 mS. Ch2 Overdrive Buffer Output, Clipped Sine Wave, 992 mVpk-pk 1 kHz. 200 mV/Div, Timebase 1 mS

6 Conclusions

In this application note we have constructed a low voltage low power overdrive pedal.

Aside from handling the analog processing for **GreenPAK's** mixed signal IC's and other digital semiconductors, **GreenPAK's** Rail to Rail Low Voltage, Low Current OpAmp's have been shown to be useful in overdrive circuitry. They are autonomous in many other applications and especially advantageous in power sensitive applications.

Battery Powered Overdrive Pedal for Guitar Effects

Revision History

Revision	Date	Description
1.0	12-Sep-2018	Initial Version

Battery Powered Overdrive Pedal for Guitar Effects

Status Definitions

Status	Definition
DRAFT	The content of this document is under review and subject to formal approval, which may result in modifications or additions.
APPROVED or unmarked	The content of this document has been approved for publication.

Disclaimer

Information in this document is believed to be accurate and reliable. However, Dialog Semiconductor does not give any representations or warranties, expressed or implied, as to the accuracy or completeness of such information. Dialog Semiconductor furthermore takes no responsibility whatsoever for the content in this document if provided by any information source outside of Dialog Semiconductor.

Dialog Semiconductor reserves the right to change without notice the information published in this document, including without limitation the specification and the design of the related semiconductor products, software and applications.

Applications, software, and semiconductor products described in this document are for illustrative purposes only. Dialog Semiconductor makes no representation or warranty that such applications, software and semiconductor products will be suitable for the specified use without further testing or modification. Unless otherwise agreed in writing, such testing or modification is the sole responsibility of the customer and Dialog Semiconductor excludes all liability in this respect.

Customer notes that nothing in this document may be construed as a license for customer to use the Dialog Semiconductor products, software and applications referred to in this document. Such license must be separately sought by customer with Dialog Semiconductor.

All use of Dialog Semiconductor products, software and applications referred to in this document are subject to Dialog Semiconductor's [Standard Terms and Conditions of Sale](#), available on the company website (www.dialog-semiconductor.com) unless otherwise stated.

Dialog and the Dialog logo are trademarks of Dialog Semiconductor plc or its subsidiaries. All other product or service names are the property of their respective owners.

© 2019 Dialog Semiconductor. All rights reserved.

Contacting Dialog Semiconductor

United Kingdom (Headquarters)
Dialog Semiconductor (UK) LTD
Phone: +44 1793 757700

Germany
Dialog Semiconductor GmbH
Phone: +49 7021 805-0

The Netherlands
Dialog Semiconductor B.V.
Phone: +31 73 640 8822

Email:
enquiry@diasemi.com

North America
Dialog Semiconductor Inc.
Phone: +1 408 845 8500

Japan
Dialog Semiconductor K. K.
Phone: +81 3 5769 5100

Taiwan
Dialog Semiconductor Taiwan
Phone: +886 281 786 222

Web site:
www.dialog-semiconductor.com

Hong Kong
Dialog Semiconductor Hong Kong
Phone: +852 2607 4271

Korea
Dialog Semiconductor Korea
Phone: +82 2 3469 8200

China (Shenzhen)
Dialog Semiconductor China
Phone: +86 755 2981 3669

China (Shanghai)
Dialog Semiconductor China
Phone: +86 21 5424 9058