

# Application Note

## Analog Front End for Heart Rate Monitor

AN-CM-307

### Abstract

*This application note describes the design procedure of an analog front end for a heart rate monitor. The circuit utilizes a commonly used technique of measuring the green light reflected from skin. A unique Auto-Trim feature of the SLG47004 allows achieving stable circuit operation in various conditions. The application note also contains test results of a hardware prototype.*

*This application note comes complete with design files which can be found in the References section*

---

## Analog Front End for Heart Rate Monitor

### Contents

<b>Abstract</b> .....	<b>1</b>
<b>Contents</b> .....	<b>2</b>
<b>Figures</b> .....	<b>3</b>
<b>1 Terms and Definitions</b> .....	<b>4</b>
<b>2 References</b> .....	<b>4</b>
<b>3 Introduction</b> .....	<b>5</b>
<b>4 Heart Rate Monitoring Techniques</b> .....	<b>5</b>
4.1 Phonocardiography .....	5
4.2 Pressure Sensing Technique .....	5
4.3 Electrocardiography .....	5
4.4 Photoplethysmography .....	5
<b>5 Proposed Design of Analog Front End</b> .....	<b>6</b>
5.1.1 LED Driver .....	7
5.1.2 Transimpedance Amplifier .....	7
5.1.3 Sample and Hold Circuit .....	7
5.1.4 High Pass Filter .....	7
5.1.5 Offset Correction Circuit .....	7
5.1.6 Biased Non-Inverting Amplifier .....	8
5.1.7 Analog Comparator with Digital Filter .....	8
5.1.8 Analog Power Supply Filter and Grounding Considerations .....	8
<b>6 Internal Blocks Configuration</b> .....	<b>8</b>
6.1 OpAmp0 and OpAmp1 Configurations .....	8
6.2 Chopper ACMP Configuration .....	8
6.3 HD Buffer Configuration .....	9
6.4 ACMP Buffer Configuration .....	9
6.5 Oscillators Configurations .....	10
6.6 Delay Macrocells Configurations .....	10
6.7 P DLY Configuration .....	11
6.8 LUTs Configurations .....	11
6.9 Digital Rheostat 0 Configuration .....	11
6.10 Analog Switch 1 Configuration .....	12
6.11 I <sup>2</sup> C Macrocell Configuration .....	12
6.12 GPIOs Configurations .....	12
<b>7 Normal Operation Mode</b> .....	<b>13</b>
<b>8 Software Simulation and Hardware Prototype Testing</b> .....	<b>13</b>
<b>9 Conclusions</b> .....	<b>15</b>
<b>Revision History</b> .....	<b>16</b>

## Analog Front End for Heart Rate Monitor

### Figures

Figure 1: Typical ECG of Healthy Heart .....	5
Figure 2: Analog Front-End Schematic .....	6
Figure 3: Analog Front End Structure.....	7
Figure 4: Operational Amplifier 0, 1 Settings.....	8
Figure 5: Chopper ACMP Settings .....	9
Figure 6: HD Buffer and OpAmp0 Vref Settings.....	9
Figure 7: ACMP1L and Vref1 Settings .....	10
Figure 8: Oscillator0 Settings .....	10
Figure 9: Delay Macrocells Settings .....	11
Figure 10: P DLY Settings .....	11
Figure 11: LUTs Settings.....	11
Figure 12: Digital Rheostat 0 Settings.....	12
Figure 13: Analog Switch 1 Settings .....	12
Figure 14: GPIOs Settings.....	12
Figure 15: Sample and Hold Phases During Normal Operation Mode .....	13
Figure 16: Simulation Results of the First Four Seconds of Operation.....	14
Figure 17: Simulation Results of the Auto-Trim Process .....	14
Figure 18: Analog (Yellow) and Digital (Pink) Output Signals of AFE Applied to Finger .....	15

---

## Analog Front End for Heart Rate Monitor

---

### 1 Terms and Definitions

AFE	Analog front end
ECG	Electrocardiogram
HR	Heart rate
IC	Integrated circuit
OpAmp	Operational amplifier
S&H	Sample and hold
TIA	Transimpedance amplifier

### 2 References

For related documents and software, please visit:

<https://www.dialog-semiconductor.com/advanced-analog-products>

Download our free [GreenPAK Designer software](#) [1] to open the .gp files [2] and view the proposed circuit design. Use the [GreenPAK development tools](#) [3] to freeze the design into your own customized IC in a matter of minutes. Dialog Semiconductor provides a complete library of application notes [4] featuring design examples as well as explanations of features and blocks within the Dialog IC.

- [1] [GreenPAK Designer Software](#), Software Download and User Guide, Dialog Semiconductor
- [2] [AN-CM-307 Analog Front End for Heart Rate Monitor.gp](#), [GreenPAK Design File](#), Dialog Semiconductor
- [3] [GreenPAK Development Tools](#), [GreenPAK Development Tools Webpage](#), Dialog Semiconductor
- [4] [GreenPAK Application Notes](#), [GreenPAK Application Notes Webpage](#), Dialog Semiconductor
- [5] [SLG47004, Datasheet](#), Dialog Semiconductor

## Analog Front End for Heart Rate Monitor

### 3 Introduction

Heart rate is one of the critical vital signs in humans. The monitoring and tracking of heart rate (HR) is a relatively simple task for modern electronics. That's why modern wearable devices like smartwatches and activity trackers widely utilize a HR monitoring function. In addition, such devices can detect possible diseases like tachycardia (fast HR), bradycardia (slow HR), arrhythmia (often changed HR), and others.

Also, HR monitors are widely used in sports. With the help of an HR measurement, athletes can define appropriate load and rest intervals.

### 4 Heart Rate Monitoring Techniques

There are several different techniques of how heart rate can be monitored. All these techniques use different types of signals.

#### 4.1 Phonocardiography

This technique uses the sound signal produced by opening and closing of heart valves. As a rule, the signal is filtered and processed with the help of DSP. After proper filtering, it's possible to detect not only heart rate, but also abnormalities of the heart.

#### 4.2 Pressure Sensing Technique

This technique utilizes a signal from a piezo sensor attached to one of the defined places on the human body, for example, on the wrist. Contraction and relaxation of the heart cause a corresponding change of pressure in the blood vessels.

#### 4.3 Electrocardiography

This technique is based on the measurement of the electric field produced by the heart. There must be two or more electrodes placed on specific points of the human body. Graphic representation of ECG consists of six peaks and valleys called P, Q, R, S, T, and U. The heart rate is measured by averaging RR interval between two R peaks (Figure 1) over a defined period (for example, 15, 30, or 60 seconds).

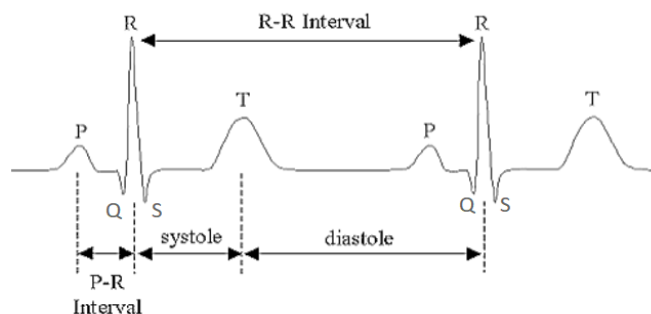

Figure 1: Typical ECG of Healthy Heart

#### 4.4 Photoplethysmography

This technique is based on the measurement of the volume variations of light reflected from the skin. When light emitted from a LED passes through a blood vessel, the received light has pulsations that correspond to heartbeat. Typically, a green or infrared LED is used as a light source because of the

## Analog Front End for Heart Rate Monitor

characteristic of blood's absorption to light with specific wavelengths. This technique is the most common way of heart rate monitoring in wearables.

The most appropriate wavelength of green light for photoplethysmography is in the range from 540 nm to 570 nm. But as a rule, the LEDs with 530 nm are used, due to the high value of luminous intensity.

### 5 Proposed Design of Analog Front End

The proposed analog front-end circuit is shown in Figure 2.

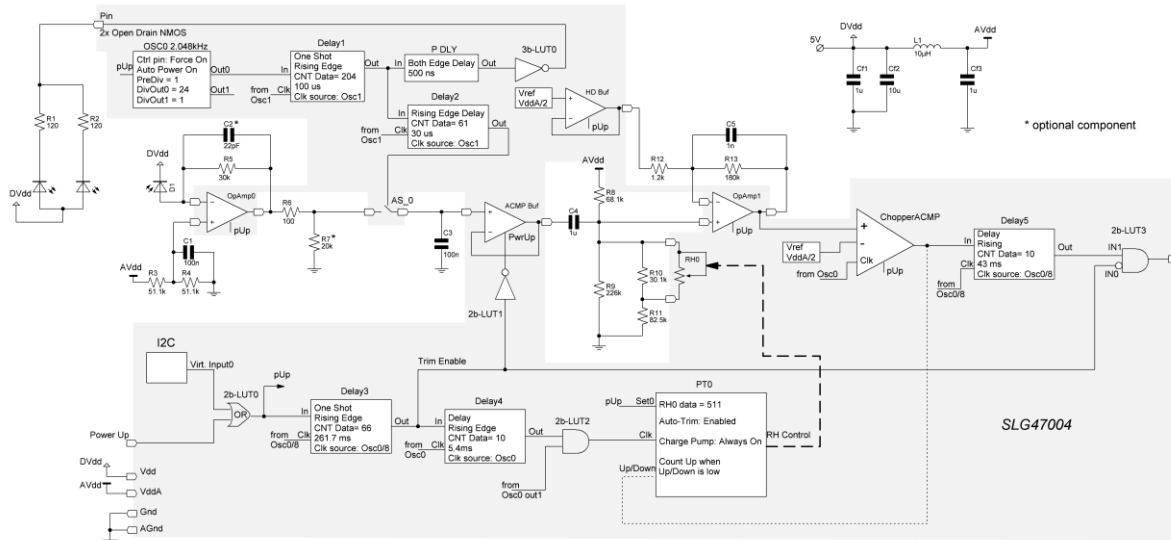
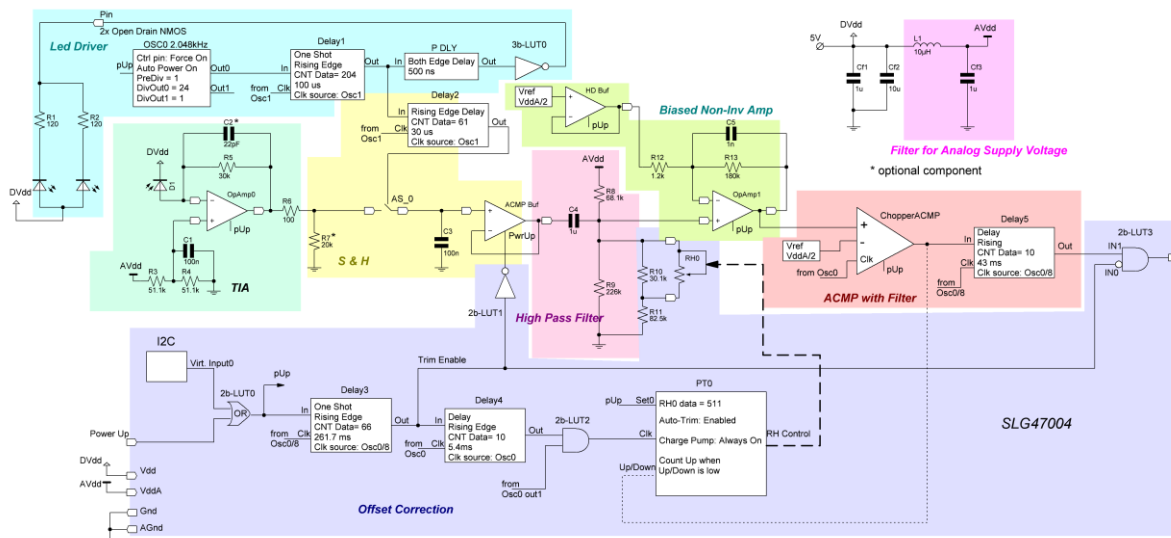

Figure 2: Analog Front-End Schematic

The circuit consists of the following parts: LED driver, transimpedance amplifier (TIA), sample and hold circuit, high pass filter, offset correction circuit, biased non-inverting amplifier, analog comparator with digital filter, and analog power supply filter. The structure of the proposed design is shown in Figure 3.



## Analog Front End for Heart Rate Monitor

Figure 3: Analog Front End Structure

### 5.1.1 LED Driver

The LED driver periodically turns on/off two green LEDs. The period is 11.7 ms (85.3 Hz). Turn on time duration is 100 us. So, the duty cycle is  $0.1/11.7 = 0.85\%$ . The operating current through each LED is 12.5 mA, giving 25 mA through one pin of the SLG47004. The average current through the pin is 213  $\mu$ A.

### 5.1.2 Transimpedance Amplifier

In this example the TIA operates in photovoltaic mode to convert small photodiode current to voltage. The photodiode part number is BPW34. It's possible to use other LEDs or photodiode, but in that case gain resistor R5 must be changed to provide an appropriate voltage level at the output.

Optional capacitor C2 increases the stability of the TIA. It's recommended to place C2 in case of stability issues of the TIA stage. The value of C2 can be calculated using the following formula:

$$C_f = \sqrt{\frac{(C_D + C_{CM} + C_{Diff})}{2\pi \cdot GBWP \cdot R_f}}$$

where  $C_D$ ,  $C_{CM}$ ,  $C_{Diff}$  - are diode capacitance, common-mode operational amplifier capacitance, and differential mode operational amplifier capacitance;

GBWP - is gain-bandwidth product of operational amplifier;

$R_f$  - is the feedback resistor.

According to the datasheet, amplifiers of the SLG47004 have  $C_{CM} = 7$  pF and  $C_{Diff} = 8$  pF. Capacitance of photodiode  $C_D = 40$  pF. GBWP = 512 kHz (setting) and  $R_f = 30$  k $\Omega$ . So  $C_f = 23.9$  pF or 22 pF (nearest standard value).

### 5.1.3 Sample and Hold Circuit

The S&H circuit consists of an analog switch, capacitor, and buffer. Sampling begins after 30 us pause when LEDs are turned on, see [Figure 15](#). During the pause, the output of the OpAmp is stabilized. When the analog switch is opened (sampling phase), the sampling capacitor C3 is charged to the voltage level at OpAmp0 output. The duration of the sampling time is 70 us.

During the hold phase the analog switch is closed. The sampling capacitor is disconnected from OpAmp0.

The buffer (ACMP buffer) eliminates the effect of the high pass filter on the sampling capacitor.

### 5.1.4 High Pass Filter

The first order high pass filter has a cutoff frequency of 2.3 Hz. The DC component of the signal after that filter is  $V_{DD}/2$  V.

### 5.1.5 Offset Correction Circuit

The correction of amplifier and buffer offset voltages is implemented by changing the resistance of one branch of the voltage divider (R9, R10, R11, and digital rheostat RH0). The configuration of the divider gives the ability to trim the system with 100 mV accuracy (worst case) of the output voltage. The divider can be simplified if high accuracy isn't required.

## Analog Front End for Heart Rate Monitor

### 5.1.6 Biased Non-Inverting Amplifier

The non-inverting amplifier has a gain of 151 and a bias voltage of  $V_{DD}/2$  (2.5 V for  $V_{DD} = 5$  V).

### 5.1.7 Analog Comparator with Digital Filter

Digital filtering of the signal is performed by Delay5, configured as rising edge delay.

### 5.1.8 Analog Power Supply Filter and Grounding Considerations

A common practice for mixed-signal circuits is to provide analog supply voltage filtered from the noise generated by the digital part of the schematic. In the current project this is done with the help of an L-C filter.

Special care must be taken when routing the ground traces. Analog and digital grounds should be connected at one point. The resistance of the trace from the common ground to the power supply source should be as minimal as possible. Also, it's recommended to use a power supply source with low output impedance.

## 6 Internal Blocks Configuration

### 6.1 OpAmp0 and OpAmp1 Configurations

OpAmp configurations are shown in [Figure 4](#).

Mode:	OpAmp mode ▾
Bandwidth Selection:	128 kHz ▾
Charge Pump Disable:	Enable CP ▾
Supporting Blocks On/Off:	Follows OpAmp ▾
Vref connection:	to IN- ▾
Vref:	VDDA * (32 / 64) ▾

Figure 4: Operational Amplifier 0, 1 Settings

### 6.2 Chopper ACMP Configuration

Chopper ACMP configuration is shown in [Figure 5](#).



## Analog Front End for Heart Rate Monitor

Chopper ACMP	
OUT polarity:	Non-inverted (OU) ▾
IN- Vref source:	OpAmp0 Vref (2.0V) ▾
Auto-Trim Channel:	Channel0 ▾
Channel 0	
IN+ CH0 source:	OpAmp1 OUT ▾
IN- CH0 source:	32/64 VDDA ▾
CH0 clock:	OSC0 ▾
Channel 1	
IN+ CH1 source:	InAmp OUT ▾
IN- CH1 source:	Ext. Vref (PIN 18 (G) ▾
CH1 clock:	Ext. Clk. (From mat) ▾

Figure 5: Chopper ACMP Settings

### 6.3 HD Buffer Configuration

HD Buffer shares the internal voltage reference with OpAmp0 macrocell. Note that in the current project internal Vref is disconnected from the OpAmp0. The power-up source for HD Buffer is the connection matrix signal. The HD Buffer and OpAmp0 Vref configurations are shown in Figure 6.

HD Buffer	VREF OPAMP0
Power up source: From matrix ▾	Enable selection: From register ▾
Power up register: Enable ▾	Register enable: Vref enable ▾
Connections	
Output: PIN 20 (GPIO6) ▾	Input voltage selection: VDDA ▾
	Output selection: VDDA * (32 / 64) ▾
	LPF enable: Enable ▾

Figure 6: HD Buffer and OpAmp0 Vref Settings

### 6.4 ACMP Buffer Configuration

To use ACMP buffer as a voltage follower, the ACMP1 and Vref1 macrocells should be configured as shown in Figure 7:

## Analog Front End for Heart Rate Monitor

A CMP1L		VREF1	
Hysteresis:	-	Power down source:	From matrix
IN+ gain:	Disable	Power down register:	Disable
Input LPF:	Disable	Force bandgap on:	Enable
Output LPF:	Disable	Source selector:	A CMP1L reference
Low power start up:	Disable	<b>Connections</b>	
Sampling mode:	Disable	Output:	PIN 15 (GPIO1)
Vrefs source selection:	VDDA	<b>Information</b>	
<b>Connections</b>		Typical ACMP thresholds	
IN+ source:	TEMP SENSOR out	V_IH (mV)	V_IL (mV)
IN- Low to High source:	Ext. Vref (PIN 12 (G	-	-
IN- High to Low source:	Ext. Vref (PIN 12 (G		

Figure 7: ACMP1L and Vref1 Settings

### 6.5 Oscillators Configurations

Oscillator1 uses default settings. Oscillator0 configuration is shown in Figure 8.

OSC0	
Control pin mode:	Force on
OSC power mode:	Auto Power On
Clock selector:	OSC
'OSC0' frequency:	2.048 kHz
'CLK' predivider by:	1
'OUT0' second divider by:	24
'OUT1' second divider by:	1

Figure 8: Oscillator0 Settings

### 6.6 Delay Macrocells Configurations

Delay configurations are shown in Figure 9.

## Analog Front End for Heart Rate Monitor

Figure 9: Delay Macrocells Settings

### 6.7 P DLY Configuration

P DLY configuration is shown in Figure 10.

Figure 10: P DLY Settings

### 6.8 LUTs Configurations

LUTs configurations are shown in Figure 11.

Figure 11: LUTs Settings

### 6.9 Digital Rheostat 0 Configuration

Digital Rheostat 0 configuration is shown in Figure 12.

## Analog Front End for Heart Rate Monitor

**Digital Rheostat0**

**Mode:** None

**Charge Pump Enable:** Always On

**Charge Pump Clock:** LPBG chopper OSC

**Auto-Trim:** Enable

**Active level for UP/DOWN:** Up when LOW

**Resistance (initial data):** 10  
(Range: 0 - 1023)

**Connections**

**UP/DOWN source:** Chopper ACMP

**Clock:** Ext. Clk. (From mat

Figure 12: Digital Rheostat 0 Settings

### 6.10 Analog Switch 1 Configuration

Analog Switch 1 configuration is shown in Figure 13.

**SWITCH1**

**Mode:** Analog Switch

**Big NMOS control:** By Matrix

**Small PMOS enable:** Enable by Matrix

**Half Bridge Dead Time Select:** Bypass

Figure 13: Analog Switch 1 Settings

### 6.11 I<sup>2</sup>C Macrocell Configuration

I<sup>2</sup>C macrocell uses default configurations.

### 6.12 GPIOs Configurations

GPIOs configurations are shown in Figure 14.

PIN 16 (GPIO2)	PIN 17 (GPIO3)	PIN 18 (GPIO4)	PIN 12 (GPIO0)	PIN 15 (GPIO1)
I/O selection: <span style="border: 1px solid #ccc; padding: 2px;">Digital output</span>	I/O selection: <span style="border: 1px solid #ccc; padding: 2px;">Analog input/outy</span>	I/O selection: <span style="border: 1px solid #ccc; padding: 2px;">Analog input/outy</span>	I/O selection: <span style="border: 1px solid #ccc; padding: 2px;">Analog input/outy</span>	I/O selection: <span style="border: 1px solid #ccc; padding: 2px;">Analog input/outy</span>
Input mode: OE = 0 <span style="border: 1px solid #ccc; padding: 2px;">None</span>	Input mode: OE = 0 <span style="border: 1px solid #ccc; padding: 2px;">Analog input/outy</span>	Input mode: OE = 0 <span style="border: 1px solid #ccc; padding: 2px;">Analog input/outy</span>	Input mode: OE = 0 <span style="border: 1px solid #ccc; padding: 2px;">Analog input/outy</span>	Input mode: OE = 0 <span style="border: 1px solid #ccc; padding: 2px;">Analog input/outy</span>
Output mode: OE = 1 <span style="border: 1px solid #ccc; padding: 2px;">2x open drain NM</span>	Output mode: OE = 1 <span style="border: 1px solid #ccc; padding: 2px;">Analog input/outy</span>	Output mode: OE = 1 <span style="border: 1px solid #ccc; padding: 2px;">Analog input/outy</span>	Output mode: OE = 1 <span style="border: 1px solid #ccc; padding: 2px;">Analog input/outy</span>	Output mode: OE = 1 <span style="border: 1px solid #ccc; padding: 2px;">Analog input/outy</span>
Resistor: <span style="border: 1px solid #ccc; padding: 2px;">Floating</span>	Resistor: <span style="border: 1px solid #ccc; padding: 2px;">Floating</span>	Resistor: <span style="border: 1px solid #ccc; padding: 2px;">Floating</span>	Resistor: <span style="border: 1px solid #ccc; padding: 2px;">Floating</span>	Resistor: <span style="border: 1px solid #ccc; padding: 2px;">Floating</span>
Resistor value: <span style="border: 1px solid #ccc; padding: 2px;">Floating</span>	Resistor value: <span style="border: 1px solid #ccc; padding: 2px;">Floating</span>	Resistor value: <span style="border: 1px solid #ccc; padding: 2px;">Floating</span>	Resistor value: <span style="border: 1px solid #ccc; padding: 2px;">Floating</span>	Resistor value: <span style="border: 1px solid #ccc; padding: 2px;">Floating</span>
PIN 20 (GPIO6)	PIN 19 (GPIO5)	PIN 21 (GPIO)		
I/O selection: <span style="border: 1px solid #ccc; padding: 2px;">Analog input/outy</span>	I/O selection: <span style="border: 1px solid #ccc; padding: 2px;">Digital output</span>	I/O selection: <span style="border: 1px solid #ccc; padding: 2px;">Digital input</span>		
Input mode: OE = 0 <span style="border: 1px solid #ccc; padding: 2px;">Analog input/outy</span>	Input mode: OE = 0 <span style="border: 1px solid #ccc; padding: 2px;">None</span>	Input mode: OE = 0 <span style="border: 1px solid #ccc; padding: 2px;">Digital in with Sch</span>		
Output mode: OE = 1 <span style="border: 1px solid #ccc; padding: 2px;">Analog input/outy</span>	Output mode: OE = 1 <span style="border: 1px solid #ccc; padding: 2px;">1x push pull</span>	Output mode: OE = 1 <span style="border: 1px solid #ccc; padding: 2px;">None</span>		
Resistor: <span style="border: 1px solid #ccc; padding: 2px;">Floating</span>	Resistor: <span style="border: 1px solid #ccc; padding: 2px;">Floating</span>	Resistor: <span style="border: 1px solid #ccc; padding: 2px;">Floating</span>		
Resistor value: <span style="border: 1px solid #ccc; padding: 2px;">Floating</span>	Resistor value: <span style="border: 1px solid #ccc; padding: 2px;">Floating</span>	Resistor value: <span style="border: 1px solid #ccc; padding: 2px;">Floating</span>		

Figure 14: GPIOs Settings

## Analog Front End for Heart Rate Monitor

### 7 Normal Operation Mode

The analog front-end starts operating either when the voltage at power-up input (GPIO) becomes high level or when I<sup>2</sup>C master sets I<sup>2</sup>C Virtual Input0 to 1.

The Auto-Trim process begins every time after a short delay (Delay4 time = 5.4 ms) when power-up input (I<sup>2</sup>C Virt. Input0) becomes high. The maximum duration of the Auto-Trim process is  $512(\text{rheostat\_code})/2048(\text{kHz\_clock}) = 250 \text{ ms}$ .

During the calibration procedure the analog switch is turned off and the resistance of the high pass filter divider is being changed until the voltage at the inverting input of Chopper ACMP ( $V_{\text{ref}}=AV_{\text{DD}}/2$ ) isn't equal to the voltage at the non-inverting input of Chopper ACMP (OpAmp1 output).

After the Auto-Trim process is done AFE begins to sense heart rate. LEDs are turned on 85 times per second during short intervals (100  $\mu\text{s}$ ). The sample and hold circuit takes samples when LEDs are turned on after a pause of 30  $\mu\text{s}$ , see Figure 15. The sample and hold principle greatly minimizes the average current consumed by the LEDs.

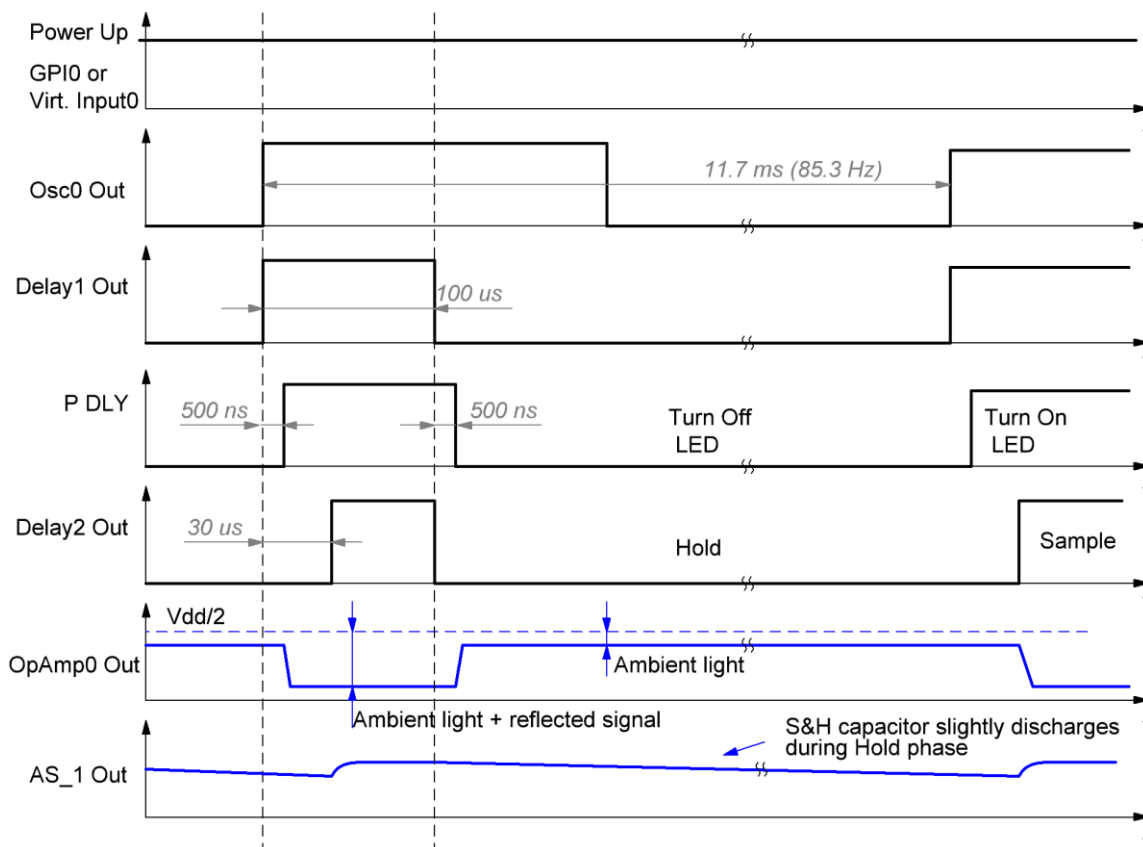

Figure 15: Sample and Hold Phases During Normal Operation Mode

### 8 Software Simulation and Hardware Prototype Testing

Figure 16 and Figure 17 show the simulation results of the first four seconds of AFE operation. The sensor (photodiode) is modeled as a sine voltage source with 10 mV amplitude. As shown in Figure 17, the desired point of trim ( $V_{\text{DD}}/2$ ) is reached 114 ms after start of the Auto-Trim process. Then the Auto-Trim system continues to operate and to switch the rheostat near the desired trim point until internal Set signal is released.

## Analog Front End for Heart Rate Monitor

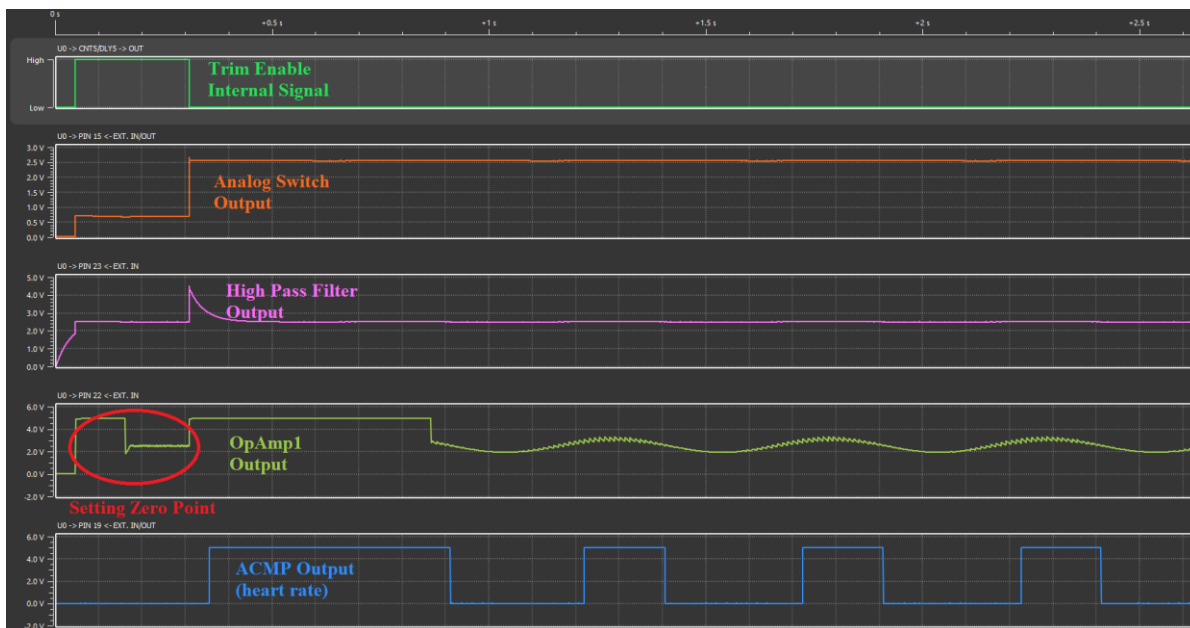

Figure 16: Simulation Results of the First Four Seconds of Operation

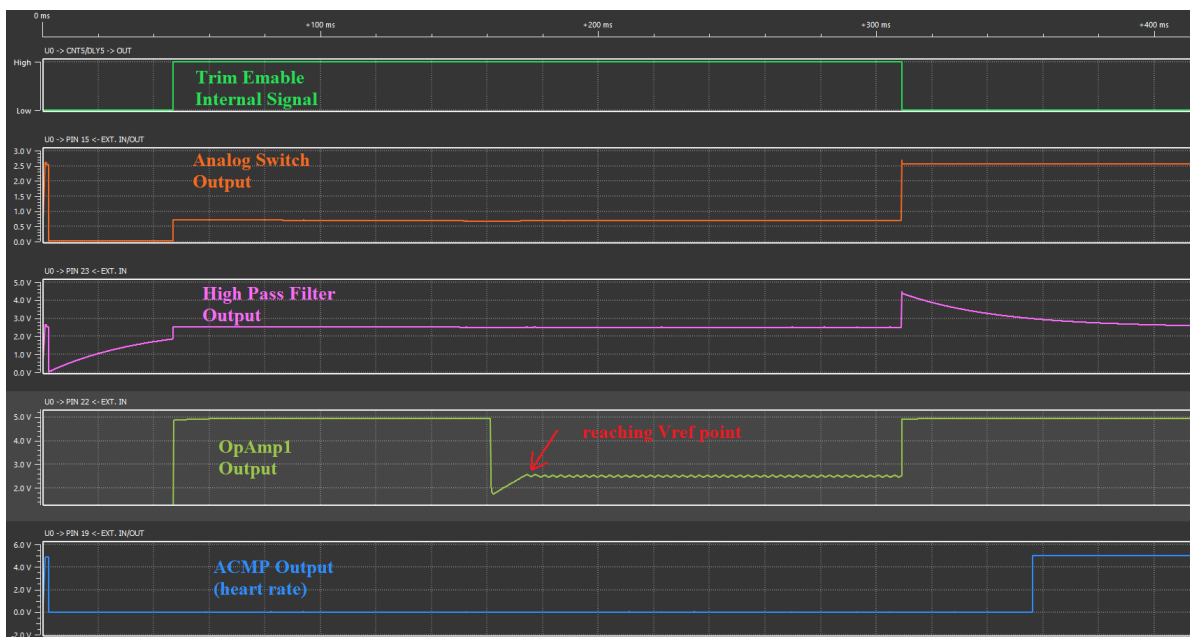
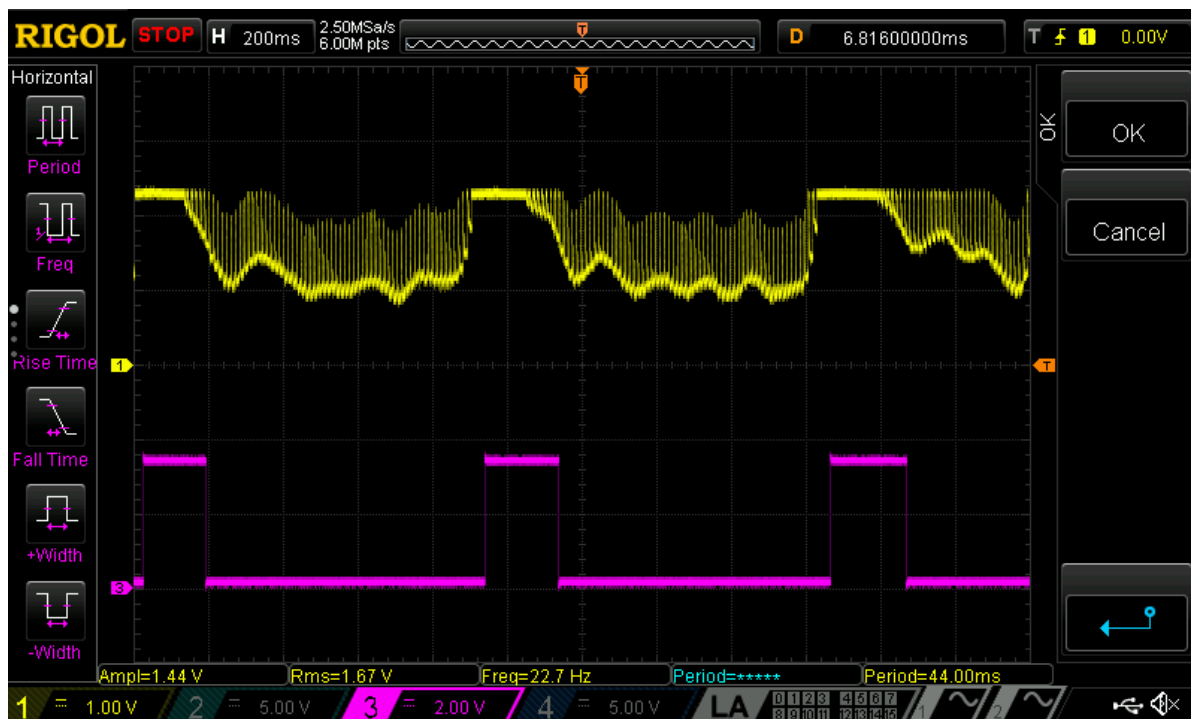

Figure 17: Simulation Results of the Auto-Trim Process

The waveforms of the hardware prototype testing are shown in [Figure 18](#).

## Analog Front End for Heart Rate Monitor



**Figure 18: Analog (Yellow) and Digital (Pink) Output Signals of AFE Applied to Finger**

The frequency of pulses at the digital output (Figure 18) is  $f_{\text{output}} = 1.063$  Hz. This frequency corresponds to the heart rate of  $(f_{\text{output}} * 60) = 64$  beats per minute.

The short voltage spikes on the analog output signal are caused by the LED's turn on/off. These spikes don't affect digital output signal since they are filtered by digital filter inside the SLG47004. If needed, these spikes can be also filtered by 1<sup>st</sup> order RC low pass filter placed at the OpAmp1 output.

The saturation region of the analog output signal is caused by the HD Buffer. This buffer has limited current sink capability. But this limitation of HD Buffer doesn't affect the digital output signal.

## 9 Conclusions

The proposed heart rate monitor is based on measuring light reflected from skin. Both signal processing and LED control are performed by a single SLG47004 IC. Additional sample and hold circuitry allows greatly reduced current consumption.

The performance of the heart rate monitor highly depends on the optical system setup: the direction of light from LEDs, the wavelength of LEDs, the distance and angle between LEDs and photodiode, and others. Also, the measurements are affected by ambient light and small movements of the sensor.

If the heart rate signal is relatively small, like a signal from the human wrist, additional software signal processing might be required.

---

**Analog Front End for Heart Rate Monitor**

**Revision History**

<b>Revision</b>	<b>Date</b>	<b>Description</b>
1.0	03-Nov-2020	Initial Version



## Analog Front End for Heart Rate Monitor

### Status Definitions

Status	Definition
DRAFT	The content of this document is under review and subject to formal approval, which may result in modifications or additions.
APPROVED or unmarked	The content of this document has been approved for publication.

### Disclaimer

Information in this document is believed to be accurate and reliable. However, Dialog Semiconductor does not give any representations or warranties, expressed or implied, as to the accuracy or completeness of such information. Dialog Semiconductor furthermore takes no responsibility whatsoever for the content in this document if provided by any information source outside of Dialog Semiconductor.

Dialog Semiconductor reserves the right to change without notice the information published in this document, including without limitation the specification and the design of the related semiconductor products, software and applications.

Applications, software, and semiconductor products described in this document are for illustrative purposes only. Dialog Semiconductor makes no representation or warranty that such applications, software and semiconductor products will be suitable for the specified use without further testing or modification. Unless otherwise agreed in writing, such testing or modification is the sole responsibility of the customer and Dialog Semiconductor excludes all liability in this respect.

Customer notes that nothing in this document may be construed as a license for customer to use the Dialog Semiconductor products, software and applications referred to in this document. Such license must be separately sought by customer with Dialog Semiconductor.

All use of Dialog Semiconductor products, software and applications referred to in this document are subject to Dialog Semiconductor's [Standard Terms and Conditions of Sale](http://www.dialog-semiconductor.com), available on the company website ([www.dialog-semiconductor.com](http://www.dialog-semiconductor.com)) unless otherwise stated.

Dialog and the Dialog logo are trademarks of Dialog Semiconductor plc or its subsidiaries. All other product or service names are the property of their respective owners.

© 2020 Dialog Semiconductor. All rights reserved.

## Contacting Dialog Semiconductor

**United Kingdom (Headquarters)**  
Dialog Semiconductor (UK) LTD  
Phone: +44 1793 757700

### Germany

Dialog Semiconductor GmbH  
Phone: +49 7021 805-0

### The Netherlands

Dialog Semiconductor B.V.  
Phone: +31 73 640 8822

### Email:

[enquiry@diasemi.com](mailto:enquiry@diasemi.com)

### North America

Dialog Semiconductor Inc.  
Phone: +1 408 845 8500

### Japan

Dialog Semiconductor K. K.  
Phone: +81 3 5769 5100

### Taiwan

Dialog Semiconductor Taiwan  
Phone: +886 281 786 222

### Web site:

[www.dialog-semiconductor.com](http://www.dialog-semiconductor.com)

### Hong Kong

Dialog Semiconductor Hong Kong  
Phone: +852 2607 4271

### Korea

Dialog Semiconductor Korea  
Phone: +82 2 3469 8200

### China (Shenzhen)

Dialog Semiconductor China  
Phone: +86 755 2981 3669

### China (Shanghai)

Dialog Semiconductor China  
Phone: +86 21 5424 9058