

Application note

Charging a nearly full battery

AN-PM-028

Abstract

When optimising and testing the charger settings on the DA9053 it is possible to see a condition where it appears that the DA9053 does not charge a nearly full battery. This application note explains which settings affect this, how to verify whether this is a real issue and if needed how to change this behaviour.

Charging a nearly full battery

Contents

Abstract	1
Contents	2
Figures	2
Terms and definitions	2
1 References	2
2 Charging the battery	3
2.1 The real battery path	4
2.2 The charge discharge cycle	5
2.3 Notes on testing	6
Revision history	7

Figures

Figure 1 Battery Resistance	4
Figure 2 Typical Li-Ion Charge Discharge Profile	5
Figure 3 DUT with additional resistance.....	6

Terms and definitions

DA905x	For this document this represents DA9021, DA9022, DA9052, DA9053 and DA9057
DUT	Device Under Test
EOC	End of Charge

1 References

- [1] DA9053-00-IDS3a_140114.pdf, Datasheet, Dialog Semiconductor, 2014
- [2] AN-PM-006-DA9053's High Efficiency Autonomous Charger.pdf, 2015

Charging a nearly full battery

2 Charging the battery

In any battery powered device, the charging process is key to managing in the active lifetime of the product. One aspect that can affect the lifetime of the battery cell and also the perceived quality of the product, is how the charging process behaves once the initial charge cycle is complete.

It is important not to trickle charge Li-ion batteries as this can lead to damage of the cell and a reduction in the overall life of the battery cell.

The DA9053 has the VCHG_DROP setting in the INPUT_CONT (R67) register that can help define this behaviour.

Before starting a charging cycle the DA9053 checks and qualifies the following parameters:

- battery temperature
- battery voltage
- charger voltage

The End of Charge (EOC) condition for the DA9053 is configured by setting the charge termination voltage and also the charge current at EOC (ICH_END).

The EOC target voltage (VCHG_BAT) is programmed into the DA9053 via the CHG_CONT (R66) register. A charging cycle starts only if the battery voltage is less than VCHG_BAT minus the VCHG_DROP value. VCHG_DROP is selectable between 100 mV and 200 mV.

In a typical system the battery voltage at end of charge will be 4.2 V. However as soon as the charge cycle terminates the voltage will drop slightly.

Charging a nearly full battery

2.1 The real battery path

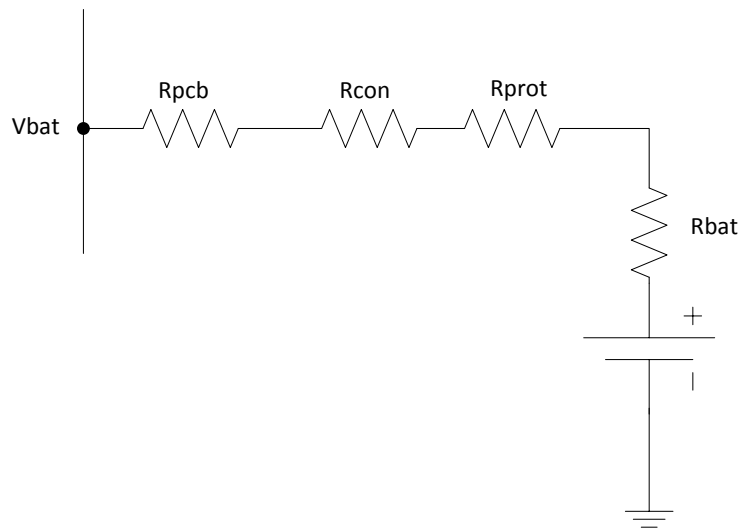

Figure 1: Battery resistance

When considering the end of charge behaviour for any given system, there are several parameters that impact this behaviour.

- battery voltage
- battery capacity
- impedance of the battery path

The impedance of the battery path is very important in determining the behaviour both under discharge conditions and also when charging.

As shown in Figure 1 the impedance of the battery path consists of various parts.

- **Rbat:** The internal resistance of the battery cell. This will increase as the battery ages.
- **Rprot:** The resistance of the protection circuit contained within most Li-ion battery packs.
- **Rcon:** The resistance of the connection to the battery pack, this can also include the resistance of any leads from the battery pack to the connector
- **Rpcb:** The resistance of the PCB trace from the battery connector to the VBAT ball on the DA9053

During charging, the effect of this resistance is to reduce the actual voltage seen on the terminals of the battery cell. During discharge, it will reduce the voltage measured on the VBAT ball of the DA9053.

The combined resistance of these parameters can be greater than 0.5 Ω .

If we consider an end of charge current of 100 mA and a path resistance of 0.5 Ω , then the actual cell voltage will be 50 mV lower than the programmed EOC voltage.

If we then consider that once charging is complete the system can draw a peak current of 100 mA from the battery. This is on top of the current supplied by the charger buck. This 100 mA would result in a drop of 50 mV from the cell voltage.

Charging a nearly full battery

Since we have already established that the cell voltage can be 50 mV less than the target voltage due to the path resistance, this additional 50 mV during discharge will lead to the VBAT voltage being measured as 100 mV below the EOC voltage.

With VCHG_DROP set to 100 mV the combination of these two effects would be sufficient to re-start the charging cycle immediately that the previous cycle completes.

2.2 The charge discharge cycle

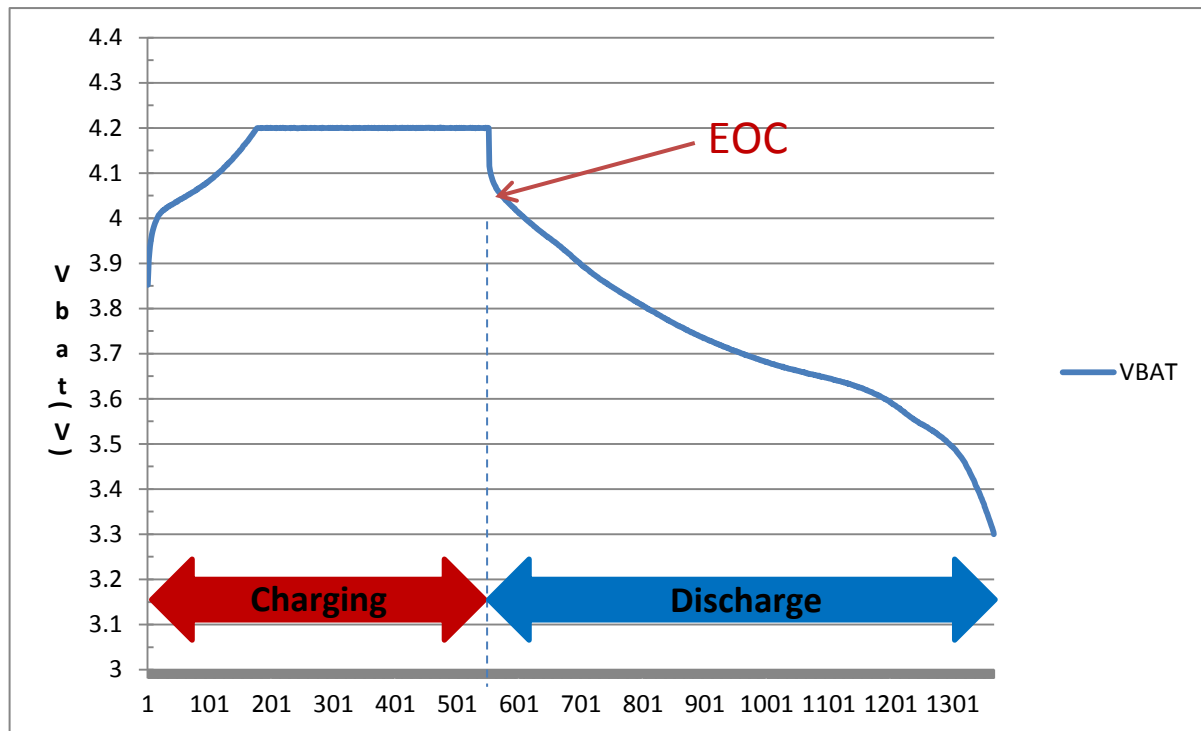

Figure 2 Typical Li-Ion charge discharge profile

Figure 2 shows a typical Charge Discharge curve from a handheld device using a 1.2 Ah Li-ion battery. The Charge termination voltage was programmed to 4.2 V. The charge termination current ICH_END was programmed to 60 mA. (The x-axis shows measurement points, which were the fixed time step of the measurement equipment).

When charging completes the voltage drop can be seen to be approximately 100 mV. In this system the charger supply was removed at EOC.

Setting VCHG_DROP to 200 mV will stop the continuous charge cycling and helps to prolong battery life.

One negative effect of setting VCH_DROP to 200 mV is that a battery that presents a voltage within 200mV of the charge termination voltage when the charger is attached will not be charged. This can also cause complications for the system software as the charger attach will have been indicated to the system. However the DA9053 will not indicate that charging has not commenced.

It is possible to optimise this behaviour by allowing the host software to re-configure the VCHG_DROP setting. In this case it is recommended that the initial setting for VCHG_DROP is set to 100 mV. This will allow charging to start as soon as a charger is attached and the voltage is 100 mV below the charge termination voltage. VCHG_DROP should then be set to 200 mV as soon as charging has started. This will reduce the chance of continual cycling when the charge cycle

Charging a nearly full battery

completes. Finally in this case, VCHG_DROP should be reset to 100 mV when a charger removal is detected.

2.3 Notes on testing

When testing this feature of the DA9053 it is common to use a source-meter or a power supply unit (PSU) with sink capability in place of the battery. This enables testing with a range of battery voltages without having to charge and discharge a real battery.

It must be noted that a source meter or PSU will not show quite the same behaviour due to the difference in series resistance of the PSU. Final verification of the charging behaviour should be made using a real battery.

A more realistic behaviour may be simulated with a PSU by placing a 0.5-1 Ω resistor in series with the PSU output, (see Figure 3). The additional resistance will simulate the resistance of the VBAT path as shown in Figure 1. This allows the correct voltage drop to be seen when the system changes from charging to discharging. The value of the resistor can be adjusted to a value that represents the real battery. A simple measurement where the battery is first measured at open circuit and then again with a load of 100 mA should give an indication of a suitable resistance.

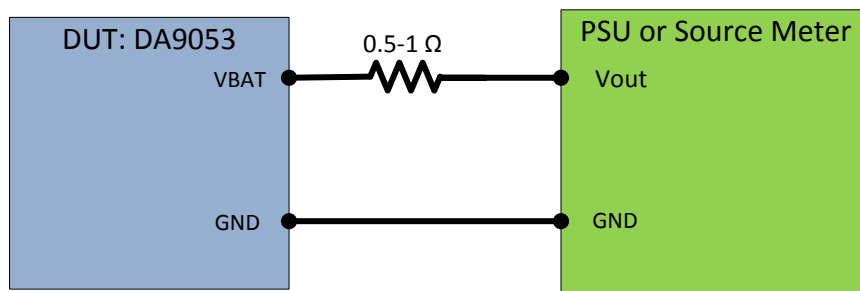

Figure 3: DUT with additional resistance.

Example measurement of 4.2 V Li-ion battery.

- Open circuit voltage of battery = 3.95 V
- Battery voltage with load of 100 mA = 3.87 V
- $R=V/I = (3.95-3.87)/0.1 = 0.08/0.1 = 0.8 \Omega$

Charging a nearly full battery**Revision history**

Revision	Date	Description
1.0	21-May-2103	Initial version.
1.1	22-Sep-15	Updated to new template. Minor text changes.

Charging a nearly full battery

Status definitions

Status	Definition
DRAFT	The content of this document is under review and subject to formal approval, which may result in modifications or additions.
APPROVED or unmarked	The content of this document has been approved for publication.

Disclaimer

Information in this document is believed to be accurate and reliable. However, Dialog Semiconductor does not give any representations or warranties, expressed or implied, as to the accuracy or completeness of such information. Dialog Semiconductor furthermore takes no responsibility whatsoever for the content in this document if provided by any information source outside of Dialog Semiconductor.

Dialog Semiconductor reserves the right to change without notice the information published in this document, including without limitation the specification and the design of the related semiconductor products, software and applications.

Applications, software, and semiconductor products described in this document are for illustrative purposes only. Dialog Semiconductor makes no representation or warranty that such applications, software and semiconductor products will be suitable for the specified use without further testing or modification. Unless otherwise agreed in writing, such testing or modification is the sole responsibility of the customer and Dialog Semiconductor excludes all liability in this respect.

Customer notes that nothing in this document may be construed as a license for customer to use the Dialog Semiconductor products, software and applications referred to in this document. Such license must be separately sought by customer with Dialog Semiconductor.

All use of Dialog Semiconductor products, software and applications referred to in this document are subject to Dialog Semiconductor's [Standard Terms and Conditions of Sale](#), unless otherwise stated.

© Dialog Semiconductor. All rights reserved.

RoHS Compliance

Dialog Semiconductor complies to European Directive 2001/95/EC and from 2 January 2013 onwards to European Directive 2011/65/EU concerning Restriction of Hazardous Substances (RoHS/RoHS2).

Dialog Semiconductor's statement on RoHS can be found on the customer portal <https://support.diasemi.com/>. RoHS certificates from our suppliers are available on request.

Contacting Dialog Semiconductor

United Kingdom (Headquarters)

Dialog Semiconductor (UK) LTD
Phone: +44 1793 757700

Germany

Dialog Semiconductor GmbH
Phone: +49 7021 805-0

The Netherlands

Dialog Semiconductor B.V.
Phone: +31 73 640 8822

Email:

enquiry@diasemi.com

North America

Dialog Semiconductor Inc.
Phone: +1 408 845 8500

Japan

Dialog Semiconductor K. K.
Phone: +81 3 5425 4567

Taiwan

Dialog Semiconductor Taiwan
Phone: +886 281 786 222

Web site:

www.dialog-semiconductor.com

Singapore

Dialog Semiconductor Singapore
Phone: +65 64 8499 29

Hong Kong

Dialog Semiconductor Hong Kong
Phone: +852 3769 5200

Korea

Dialog Semiconductor Korea
Phone: +82 2 3469 8200

China (Shenzhen)

Dialog Semiconductor China
Phone: +86 755 2981 3669

China (Shanghai)

Dialog Semiconductor China
Phone: +86 21 5424 9058