



Design Practices for Using a LONWORKS® Free Topology Channel on Trains

August 2004

LONWORKS Engineering Bulletin

Introduction

This bulletin discusses LONWORKS TP/FT-10 free topology channel networks on trains and is a companion piece to Echelon's free topology user's guides and data books. For complete design information, including PCB layout guidelines, please see the list of user's guides and data books referenced at the end of this bulletin.

Using FT 3120® and FT 3150® Free Topology Smart Transceivers

Due to the increased noise immunity of the Free Topology Smart Transceiver, Echelon strongly recommends that all new designs use the FT 31xx Smart Transceiver in lieu of using a standard Neuron® Chip and an FTT-10A Free Topology Transceiver. Echelon's Free Topology Smart Transceiver typically offers ten times greater immunity to electrical and magnetic interference than the FTT-10A transceiver.

Figure 1 shows the required circuit interconnections when using an FT 3120 or FT 3150 Free Topology Smart Transceiver for train applications.

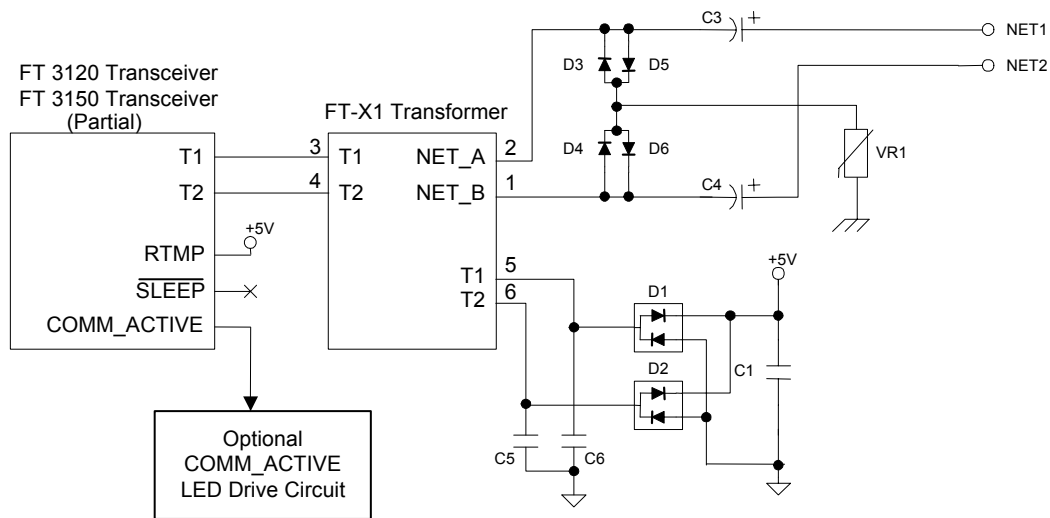

Figure 1. Partial FT 3120 and FT 3150 Free Topology Smart Transceiver Interconnection

Table 1. FT 3120 and FT 3150 Free Topology Smart Transceiver External Components

Name	Value	Comments
C1	0.1 μ F for +5VDC decoupling	V _{CC} decoupling capacitor for ESD protection diodes D1 – D2
VR1	470V MOV, 5mm, 40pF (typ.)	Panasonic ERZV05D471, Digi-Key P7186-ND or equivalent
C3, C4	22 μ F, \geq 50V, polar	DC blocking capacitors; see text
C5, C6	56pF, 5%, NPO or COG	To enable EN61000-4-6 Level 3
D1, D2	BAV99, IN4148-equivalent	ESD Transient clamping diodes
D3, D4, D5, D6	BAV99, IN4148-equivalent IN4934, IN4935, FR1D, RS1D, RS1DB	Differential network clamping diodes: For up to 2kV Surge Protection For up to 6kV Surge Protection

In figure 1, capacitors C3 and C4 are used to provide DC voltage isolation for the FT 3120 and FT 3150 Smart Transceiver in the event of a DC power fault on the network wires. The capacitors are required to meet the LONMARK® interoperability guidelines for the TP/FT-10 channel. Two polar capacitors are used to protect against a DC voltage of either polarity, while providing a total capacitance of 11 μ F.

Capacitors C5 and C6 ensure that the FT 3120 and FT 3150 Smart Transceivers support EN61000-4-6 Level 3. Note that unlike the FTT-10A transceiver, the common mode noise immunity of the FT 3120 and FT 3150 Smart Transceivers is **not** significantly improved by the addition of the common mode choke specified in the *LONWORKS FTT-10A Free Topology Transceiver User's Guide*. Therefore, there is no requirement to use the choke in train applications when using the FT 3120 or FT 3150 Smart Transceiver.

Network Input Protection Circuit Location – (Components D3 – D6, C3 – C4, and VR1)

The network input protection circuits listed above should be placed as close as possible to the FT-X1 Transformer. However, in cases where the chassis ground connection (the ground for VR1) is not available near the FT-X1 Transformer, these input protection devices can be placed near the chassis ground connections and the NET_A and NET_B traces can be run to the FT-X1 Transformer. Echelon advises that this distance be kept as short as possible to achieve optimum performance.

Transmit (TX) /Receive (RX) LEDs

Figure 2 shows the optional COMM_ACTIVE LED driver circuit block referred to in figure 1, and should be used if TX and RX LEDs are desired.

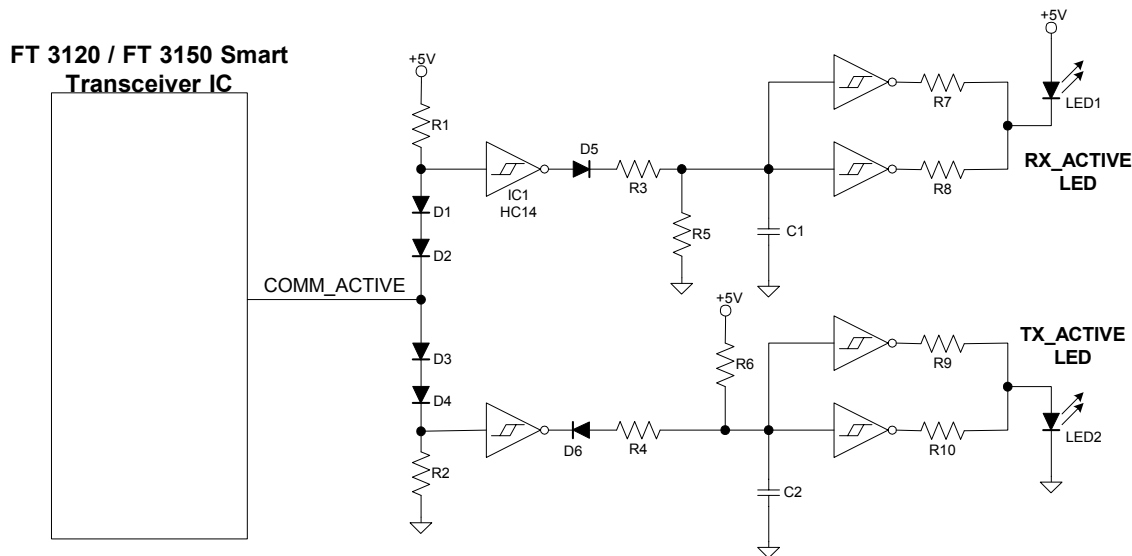

Figure 2. Optional COMM_Active LED Drive Circuit

Table 2. COMM_Active Circuit Component Values

Component Names	Value
R1, R2	10kΩ
R3, R4	1kΩ
R5, R6	220kΩ
R7, R8, R9, R10	470Ω
C1, C2	0.1μF
D1, D2, D3, D4, D5, D6	IN4148-equivalent or BAV-99-equivalent
IC1	74HC14

Note: All resistors are $\geq 1/10$ Watt. Resistor tolerances can be 1% or 5%.

The COMM_ACTIVE LED drive circuit in figure 2 is for interfacing the FT 3120 or FT 3150 Smart Transceiver COMM_ACTIVE pin to TX_ACTIVE and RX_ACTIVE LEDs to provide visual indication of physical-layer transceiver activity.

The COMM_ACTIVE pin is normally in a high-impedance state: it is driven high for the duration of a transmit packet, and is driven low for the duration of the receive packet. The

COMM_ACTIVE pin is driven low during the reception of a packet from the network, whether or not that packet is addressed to the device, and regardless of whether the packet has a valid CRC. (A valid CRC can only be checked when the entire packet has been received.) Electrical and mechanical specifications for the Smart Transceivers and the pin number for the COMM_ACTIVE signal are documented in the *FT 3120 and FT 3150 Smart Transceiver Data Book*.

Using the FTT-10A Free Topology Transceiver with a Neuron Chip

Although Echelon encourages completion of all new designs with the more robust FT 3120 or FT 3150 Smart Transceiver, existing designs using the FTT-10A Free Topology Transceiver and a Neuron Chip require the circuit shown in figure 3.

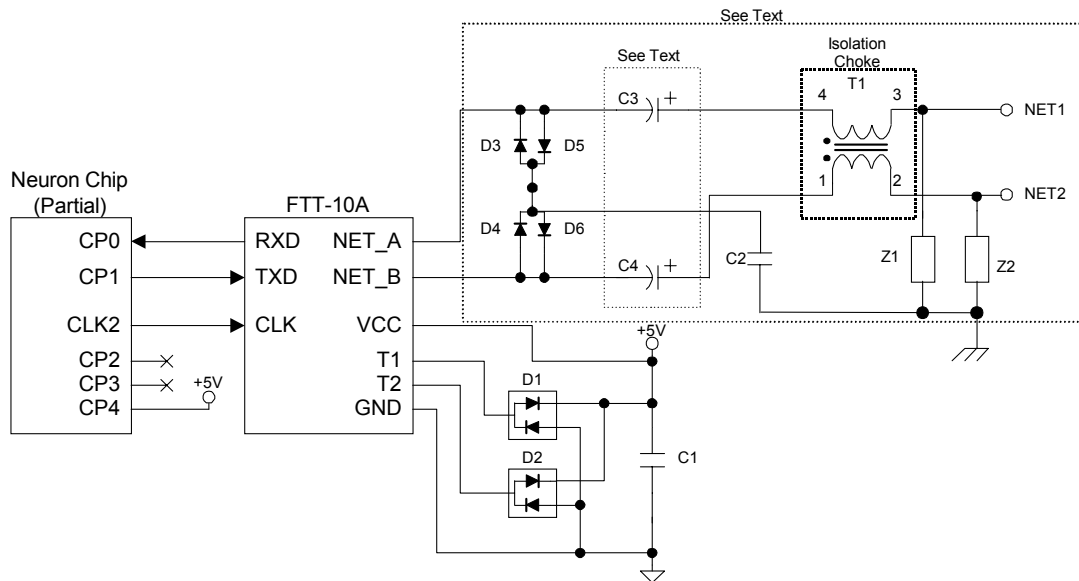

Figure 3. Partial FTT-10A Transceiver Interconnection Using Fast Surge Protectors

Table 3. Partial FTT-10A Transceiver External Components

Name	Value	Comments
C1	0.1 μ F for +5VDC decoupling	Power supply decoupling capacitor for FTT-10A transceiver
C2	1000pF, 2kV	ESD snubber capacitor
C3, C4	22 μ F, \geq 50V, polar	DC blocking capacitors; see text
D1, D2	BAV99 or 1N4148-equivalent	Transient clamping diodes; BAV99LT1 (National or Motorola), BAV99LT (Sprague), or equivalent
D3, D4, D5, D6	IN4934, IN4935	Fast switching rectifiers (General Instruments); Vishay-Liteon SMT diodes FR1D, RS1D, RS1DB
T1	See Appendix A of the <i>FTT-10A Free Topology Transceiver User Guide</i>	Common Mode Choke. A list of suppliers is provided in Appendix A of the FTT-10A user's guide.
Z1, Z2	DSP-301N	Fast surge protectors with microgap (source: Mitsubishi Materials Corporation) United States Phone: +1-487-0200 United States Fax: +1-847-577-0201 London Phone: +44-171-236-0130

Train applications cannot use PCB spark gaps due to the need for conformal coating or potted PCBs. In figure 3, the spark gaps have been replaced with encapsulated discharge devices Z1 and Z2 which are connected to chassis ground. Each of these devices has a discharge value of approximately 300 volts and introduces <1pF of capacitance to ground. Also note that diodes D3 through D6 are fast 1A rectifiers which survive Level 3 surge voltages (see chapter 5 of the *LONWORKS FTT-10A Free Topology Transceiver User's Guide*) and load the network differentially with less than 150pF. These rectifiers are required to protect the FTT-10A transceiver from surge voltages seen differentially across Net1 and Net2 as a result of asymmetric firing of the discharge devices in the presence of surge voltages coupled onto the network wiring. Z1 and Z2 should be located near the entry points of the network wiring with a low impedance path to chassis ground (or, alternately, to star ground near star ground center). The external components for figure 3 are shown in table 3.

The clock, reset, and power supply bypass circuits in the above circuit do not comprise a complete schematic since they will vary depending on the Neuron Chip type and application. For complete Neuron Chip application schematics and information, refer to the *Neuron Chip Databook*, available from Toshiba or Cypress Semiconductor. See chapter 3 of the *LONWORKS FTT-10A Free Topology Transceiver User's Guide* for mechanical specifications and PCB footprint information.

In the above schematic, capacitors C3 and C4 are used to provide DC voltage isolation for the FTT-10A transceiver to protect the transformer in the event of a DC fault on the network. The capacitors are required to meet LONMARK interoperability guidelines. Two polar capacitors are used to protect against the application of DC of either polarity while providing total net capacitance of 11 μ F.

Network Input Protection Circuit Location – (Components D3 – D6, C2 – C4, T1, Z1 – Z2)

These components should be placed as close as possible to the FTT-10A transceiver. However, in cases where the chassis ground connection (the ground for C2) is not available near the FTT-10A transceiver, these input protection devices can be placed near the chassis ground connection and the NET_A and NET_B traces can be run to the FTT-10A transceiver. This distance should be kept as short as possible.

Cable Selection

Echelon has qualified several cables for use with free topology networks. However, the unique safety requirements of trains may require cables that have not been pre-approved by Echelon. Echelon's *Junction Box and Wiring Guidelines for Twisted Pair LONWORKS Networks* engineering bulletin provides a list of all approved cable types, along with cable vendor contact information. When selecting custom cable, "Level 4" cable specifications described in the engineering bulletin must be followed verbatim.

Shielded Termination

Typically, shielded termination is used on trains to minimize the impact of strong electromagnetic fields. Echelon recommends that only shielded cable be used and that the network wiring use a doubly-terminated bus network configuration. If unshielded cable is used, Echelon's standard Bus or Free Topology Termination (part numbers 44100 and 44101) may be used. However, if a cable with an overall shield is used, a custom network termination (figure 4) is required to properly terminate both the network twisted pair wiring and the shield. The goal of the custom circuit is to match the differential and common mode characteristic impedances of the cable. Consult with the cable manufacturer to learn the impedances of the selected cables and then validate the specifications by, measuring the impedance of the shield-to-car body during system design and prototyping. The characteristic impedance of the cable shield to the car body will depend on spacings, nearby metal surfaces, and plenums. Use the circuits shown in figure 4 when terminating a shielded cable. Typical component values are shown, and a description of how to calculate actual cable values is included after figure 5.

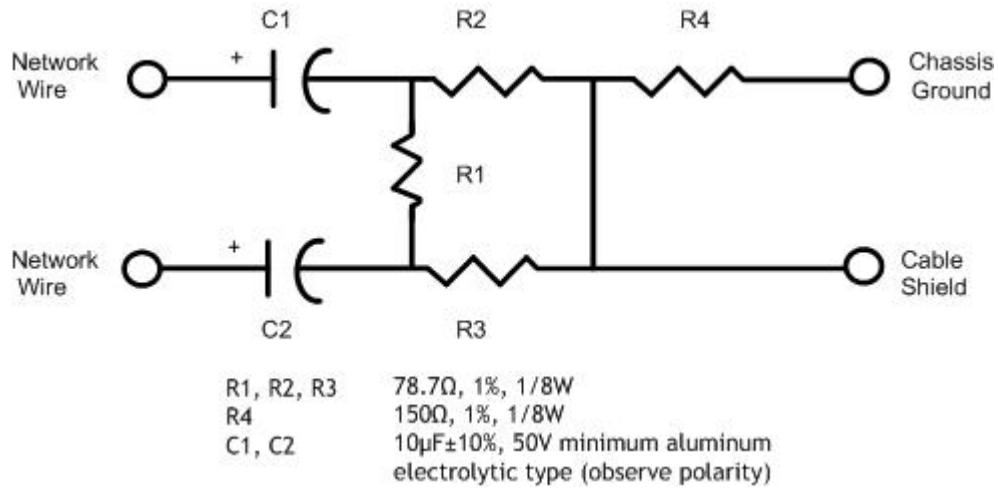

Figure 4. Free Topology Network Terminator for use with Shielded Cables (One Terminator Used)

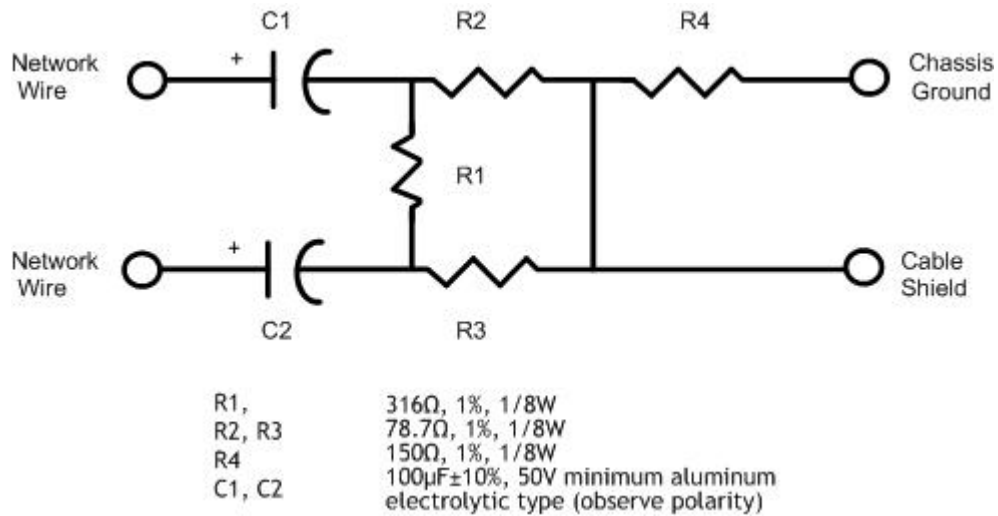

Figure 5. Bus Topology Network Terminators for use with Shielded Cables (Two Terminators Required)

Component Calculations

There are three impedances involved in calculating the cable impedance.

Z1 – Differential Impedance	The balanced characteristic impedance measured between the network twisted pair wires. The cable manufacturer typically supplies this parameter, which should be approximately 102Ω for Level 4 cable.
Z2 – Common Mode Impedance	The unbalanced characteristic impedance measured from the network pair to the shield, with the network pair shorted together. The cable manufacturer typically supplies this parameter. If not, it can be measured with a time domain reflectometer (TDR) or other characteristic impedance measuring device.
Z3 – Shield-to-Ground Impedance	The unbalanced characteristic impedance measured between the cable shield and the car body or ground plane. This parameter cannot be properly measured until the cable is actually installed in the train. The measurement depends on the average distance from the cable shield to the adjacent car body metal, and on cable routing. For the Z3 measurement, selection of the value should be delayed until the cable is installed in the first vehicle, then, using a TDR or other test equipment, the actual Z3 characteristic impedance should be measured.

After Z1 through Z3 are known, the values of R1 through R4 can be determined by using the following formula:

$$Z2 = R2 \parallel R3 = R2/2 = R3/2 \text{ (because } R2=R3\text{)}$$

$$Z3 = R4$$

$$Z1 = R1 \parallel (R2 + R3)$$

Reference Documentation

LONWORKS FTT-10A Free Topology Transceiver User's Guide, part number 078-0156-01.

FT 3120 and FT 3150 Smart Transceiver Data Book, part number 005-0139-01.

Junction Box and Wiring Guidelines for Twisted Pair LONWORKS Networks Engineering Bulletin, part number 005-0023-01.

Neuron Chip Databook (available from Toshiba and Cypress Semiconductor)

Disclaimer

Echelon Corporation assumes no responsibility for any errors contained herein. Echelon makes no representation and offers no warranty of any kind regarding any of the third-party components mentioned in this document. These components are suggested only as examples of usable devices. The use of these components or other alternatives is at the customer's sole discretion. Echelon also does not guarantee the designs shown in this document. No part of this document may be reproduced, translated, or transmitted in any form without permission from Echelon.