

AC/DC Digital Power Controller for Single-Stage High Power Factor Dimmable LED Drivers

1.0 Features

- Isolated/non-isolated offline 120V_{AC}/230V_{AC} LED driver up to 45W output power
- Wide line frequency range (from 45Hz to 66Hz)
- Meets IEC61000-3-2 Current Harmonic requirement
- Total harmonic distortion < 20% with PF > 0.92
- Wide dimmer compatibility
 - » Leading-edge dimmer
 - » Trailing-edge dimmer
- Selectable dimming range of 1% to 100% or 10% to 100%
- Resonant control to achieve high efficiency (typical > 82% without dimmer)
- Over-temperature LED current foldback
- Small solution size
 - » Single-stage topology reduces part counts
 - » 90kHz maximum switching frequency enables the use of a small transformer
- Primary-side sensing eliminates the need for opto-isolator feedback
- Tight LED current regulation ($\pm 5\%$)
- Fast start-up (< 0.5s without dimmer)
- Compatible with NEMA SSL6 dimming curve standard
- Multiple protection features that include:
 - » LED open-circuit and short-circuit protection
 - » Over-current protection
 - » Over-temperature protection
 - » Current sensing resistor short-circuit protection
- AC line over-voltage protection

2.0 Description

The iW3600 is a single-stage, high-performance AC/DC offline power supply controller for dimmable LED luminaires. It applies advanced digital control technology to detect the dimmer type, which provides dynamic impedance to interface with the dimmer and control the LED brightness at the same time.



With advanced dimmer detection technology, the iW3600 can operate with most wall dimmers including leading-edge dimmers (R-type or R-L type) and trailing-edge dimmers (R-C type). In addition, the iW3600's cycle-by-cycle waveform analysis technology allows for fast dimmer setting response. When no dimmer is on the line, the iW3600 optimizes the power factor and minimizes the current harmonic distortion to the AC line. Furthermore, in no dimmer condition, output current is regulated at nominal output current value over a wide input voltage range.

The iW3600 operates the main power converter that delivers current to the LED load in quasi-resonant mode to provide high power efficiency and minimize electro-magnetic interference (EMI). The commonly utilized converter topologies for iW3600 are buck-boost and flyback. It uses Dialog's patented PrimAccurate™ primary-side sensing technology to achieve excellent LED current regulation under different AC line and LED load voltages, without using a secondary-side feedback circuit and thus eliminating the need for an opto-coupler.

The iW3600 minimizes the external components count by simplifying the EMI filter with Dialog's EZ-EMI® technology. The intelligent dimmer detection technology minimizes the bleeding power loss. Additionally, the digital control loop of the iW3600 maintains stable overall operating conditions without the need for loop compensation components.

3.0 Applications

- Dimmable LED retrofit lamps up to 45W
- Dimmable LED luminaires up to 45W



AC/DC Digital Power Controller for Single-Stage High Power Factor Dimmable LED Drivers

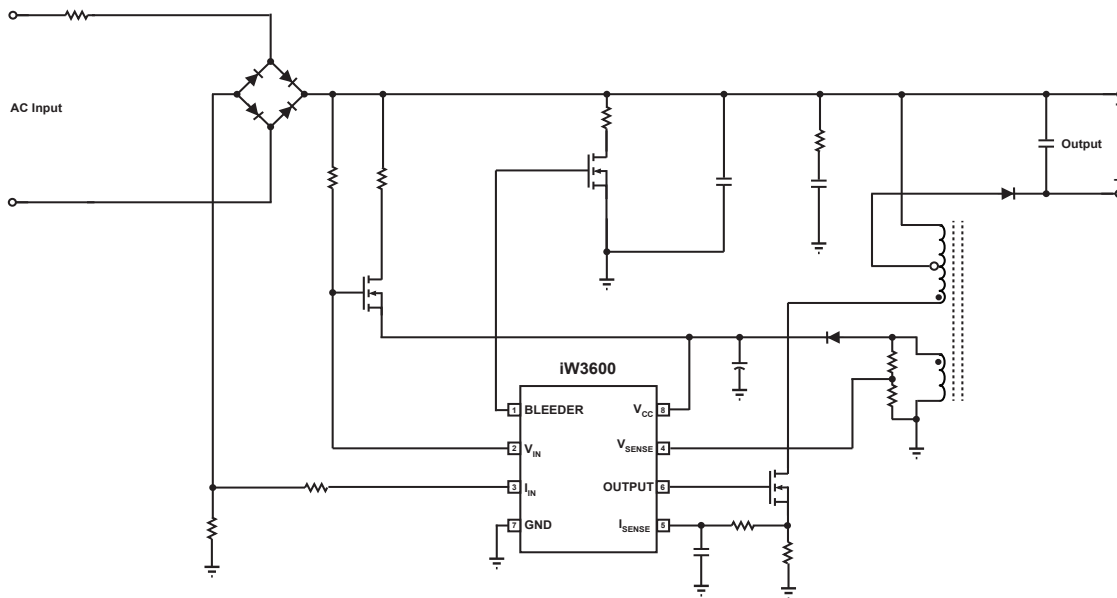

Figure 4.1 : iW3600 Simplified Application Circuit

4.0 Pinout Description

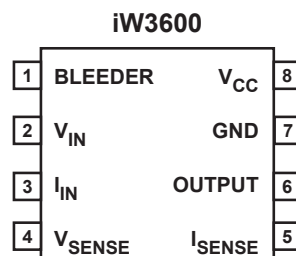

Figure 4.2 : 8-Lead SOIC-8 Package

Pin #	Name	Type	Pin Description
1	BLEEDER	Output	Gate drive for Bleeder switch
2	V_{IN}	Analog Input	Rectified AC line voltage sense
3	I_{IN}	Analog Input	Rectified AC line current sense
4	V_{SENSE}	Analog Input	Auxiliary winding voltage sense
5	I_{SENSE}	Analog Input	Primary side current sense
6	OUTPUT	Output	Gate drive for main MOSFET switch
7	GND	Ground	Ground
8	V_{CC}	Power	Power supply for control logic

AC/DC Digital Power Controller for Single-Stage High Power Factor Dimmable LED Drivers

5.0 Absolute Maximum Ratings

Absolute maximum ratings are the parameter values or ranges which can cause permanent damage if exceeded. For maximum safe operating conditions, refer to iW3600 datasheet.

Parameter	Symbol	Value	Units
DC supply voltage range (pin 8)	V_{CC}	-0.3 to 18	V
OUTPUT (pin 6)		-0.3 to V_{CC}	V
BLEEDER output (pin 1)		-0.3 to V_{CC}	V
V_{SENSE} input (pin 4, $I \leq 10\text{mA}$)		-0.7 to 4.0	V
V_{IN} input (pin 2)		-0.3 to 18	V
I_{SENSE} input (pin 5)		-0.3 to 4.0	V
I_{IN} input (pin 3)		-0.7 to 4.0	V
Power dissipation at $T_A \leq 25^\circ\text{C}$		TBD	mW
Maximum junction temperature	T_{JMAX}	150	$^\circ\text{C}$
Storage temperature	T_{STG}	-65 to 150	$^\circ\text{C}$
Thermal Resistance Junction-to-Ambient [Still Air]	θ_{JA}	160	$^\circ\text{C}/\text{W}$
ESD rating per JEDEC JESD22-A114		$\pm 2,000$	V
Latch-up test		100	mA

AC/DC Digital Power Controller for Single-Stage High Power Factor Dimmable LED Drivers

6.0 Physical Dimensions

8-Lead Small Outline (SOIC) Package

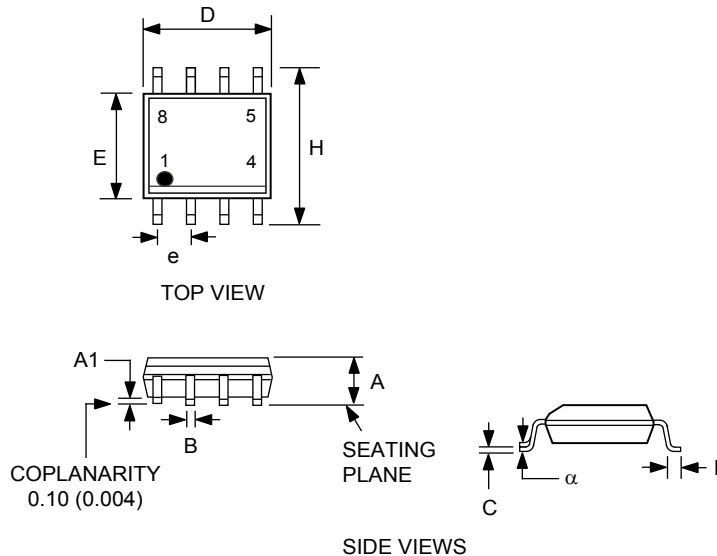

Symbol	Inches		Millimeters	
	MIN	MAX	MIN	MAX
A	0.053	0.069	1.35	1.75
A1	0.0040	0.010	0.10	0.25
B	0.014	0.019	0.35	0.49
C	0.007	0.010	0.19	0.25
D	0.189	0.197	4.80	5.00
E	0.150	0.157	3.80	4.00
e	0.050 BSC		1.27 BSC	
H	0.228	0.244	5.80	6.20
L	0.016	0.049	0.40	1.25
α	0°	8°		

Compliant to JEDEC Standard MS12F

Controlling dimensions are in inches; millimeter dimensions are for reference only

This product is RoHS compliant and Halide free.

Soldering Temperature Resistance:

[a] Package is IPC/JEDEC Std 020D moisture sensitivity level 1

[b] Package exceeds JEDEC Std No. 22-A111 for solder immersion resistance; package can withstand 10 s immersion < 260°C

Dimension D does not include mold flash, protrusions or gate burrs. Mold flash, protrusions or gate burrs shall not exceed 0.15 mm per end. Dimension E1 does not include interlead flash or protrusion. Interlead flash or protrusion shall not exceed 0.25 mm per side.

The package top may be smaller than the package bottom. Dimensions D and E1 are determined at the outermost extremes of the plastic body exclusive of mold flash, tie bar burrs, gate burrs and interlead flash, but including any mismatch between the top and bottom of the plastic body.

7.0 Ordering Information

Part Number	Options	Package	Description
iW3600-00	120V _{AC} Input	SOIC-8	Tape & Reel ¹
iW3600-01	230V _{AC} Input	SOIC-8	Tape & Reel ¹
iW3600-04	Lower Bleeder Loss Options; 120V _{AC} /230V _{AC} Input	SOIC-8	Tape & Reel ¹

Note 1: Tape & Reel packing quantity is 2,500/reel. Minimum ordering quantity is 2,500.

AC/DC Digital Power Controller for Single-Stage High Power Factor Dimmable LED Drivers

Disclaimer

Information in this document is believed to be accurate and reliable. However, Dialog Semiconductor does not give any representations or warranties, expressed or implied, as to the accuracy or completeness of such information. Dialog Semiconductor furthermore takes no responsibility whatsoever for the content in this document if provided by any information source outside of Dialog Semiconductor.

Dialog Semiconductor reserves the right to change without notice the information published in this document, including without limitation the specification and the design of the related semiconductor products, software and applications.

Applications, software, and semiconductor products described in this document are for illustrative purposes only. Dialog Semiconductor makes no representation or warranty that such applications, software and semiconductor products will be suitable for the specified use without further testing or modification. Unless otherwise agreed in writing, such testing or modification is the sole responsibility of the customer and Dialog Semiconductor excludes all liability in this respect.

Customer notes that nothing in this document may be construed as a license for customer to use the Dialog Semiconductor products, software and applications referred to in this document. Such license must be separately sought by customer with Dialog Semiconductor.

All use of Dialog Semiconductor products, software and applications referred to in this document are subject to Dialog Semiconductor's [Standard Terms and Conditions of Sale](#), unless otherwise stated.

© Dialog Semiconductor (UK) Ltd. All rights reserved.

RoHS compliance

Dialog Semiconductor complies to European Directive 2001/95/EC and from 2 January 2013 onwards to European Directive 2011/65/EU concerning Restriction of Hazardous Substances (RoHS/RoHS2).

Dialog Semiconductor's statement on RoHS can be found on the customer portal <https://support.diasemi.com/>. RoHS certificates from our suppliers are available on request.

Contacting Dialog Semiconductor

United Kingdom

Dialog Semiconductor (UK) Ltd
Phone: +44 1793 757700

Germany

Dialog Semiconductor GmbH
Phone: +49 7021 805-0

The Netherlands

Dialog Semiconductor B.V.
Phone: +31 73 640 88 22

Email

info_pcbg@diasemi.com

North America

Dialog Semiconductor Inc.
Phone: +1 408 845 8500

Japan

Dialog Semiconductor K. K.
Phone: +81 3 5425 4567

Taiwan

Dialog Semiconductor Taiwan
Phone: +886 8178 6222

Web site:

www.dialog-semiconductor.com

Singapore

Dialog Semiconductor Singapore
Phone: +65 64849929

Hong Kong

Dialog Semiconductor Hong Kong
Phone: +852 2607 4271

Korea

Dialog Semiconductor Korea
Phone: +82 2 3469 8200

China

*Dialog Semiconductor
(Shenzhen)*
Phone: +86 755 2981 3669

*Dialog Semiconductor
(Shanghai)*
Phone: +86 21 5178 2561