

Off-Line Digital Power Controller for LED Driver with High Power Factor and Low-Ripple Current

1.0 Features

- All-in-one non-dimmable low-cost off-line LED driver (isolated and non-isolated applications)
- Supports universal input voltage range ($90V_{AC}$ to $277V_{AC}$) and output power up to 20W
- High power factor (PF) with low current-ripple control technology
- User-configurable power factor setting (>0.7 to >0.9)
- User-configurable over-temperature protection (OTP) with temperature-current derating
- Very tight LED current regulation ($\pm 5\%$) across line and load, and within primary inductance tolerance ($\pm 20\%$)
- Isolated design without opto-coupler
- Supports wide range of LED numbers with tight current regulation
- Stabilized LED current-ripple control without visible shimmer or flicker
- Active start-up scheme enables fastest possible start-up
- 72kHz maximum PWM switching frequency with quasi-resonant operation
- Dynamic base current control to drive low-cost BJT
- EZ-EMI[®] design enhances manufacturability
- Built-in single-point fault protection features: LED open-/short-circuit protection and over-current protection
- No audible noise over entire operating range

2.0 Description

The iW3628 is a high performance, single-stage AC/DC power controller for LED luminaires with power factor (PF) correction. The device uses digital control technology to build unique hybrid mode control in PWM flyback power supplies to achieve high power factor meanwhile minimizing LED current ripple. This distinctive control approach enables the capability for users to make trade-offs between PF and LED current ripple in a single-stage design. It can achieve excellent LED current regulation over line and load variation, without the need for secondary feedback circuit. The built-in temperature sensor along with control logic can automatically adjust output current in real-time without visible flicker during the process. The iW3628 operates in quasi-resonant mode to provide high efficiency along with a number of key built-in protection features while minimizing the external component count, simplifying EMI design, and lowering the total bill of material cost. It also eliminates the need for loop compensation components while maintaining stability over all operating conditions. The built-in power limit function enables optimized transformer design in universal off-line applications with input voltage from $90V_{AC}$ to $277V_{AC}$.

Dialog's innovative proprietary technology maximizes the iW3628 performance in a thermal-enhanced SOIC-8 package. The iW3628 offers two multi-function pins allowing users to configure PF and OTP as required with no cost or size impact, thereby providing design flexibility. The active start-up scheme enables the shortest possible start-up time without sacrificing active efficiency.

3.0 Applications

- Solid-state LED lighting
- LED lighting ballast

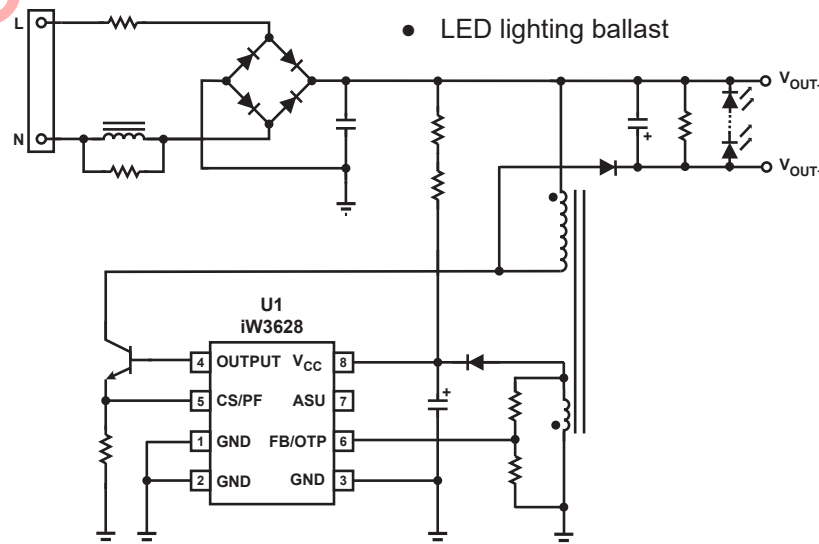

Figure 3.1: iW3628 Typical Application Circuit (Non-Isolated Application)

Off-Line Digital Power Controller for LED Driver with High Power Factor and Low-Ripple Current

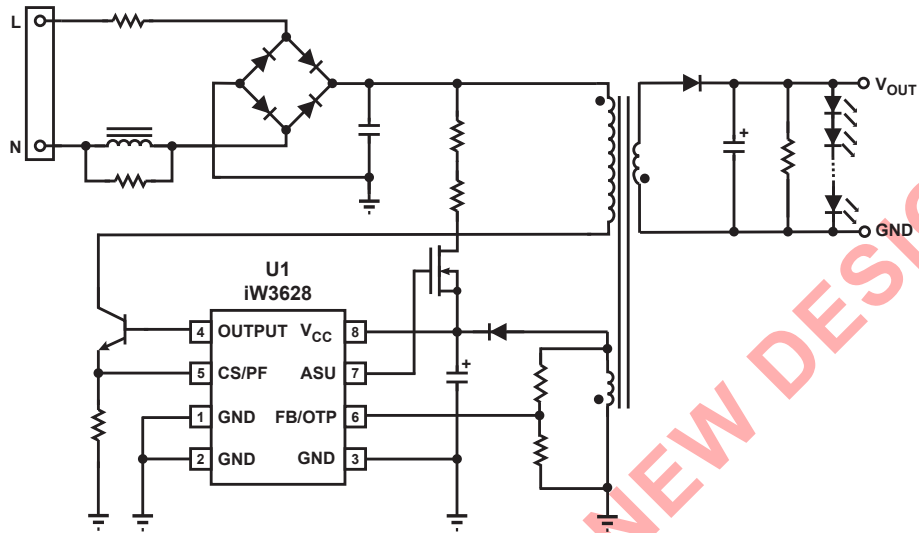

Figure 3.2: iW3628 Typical Application Circuit (Isolated Application)

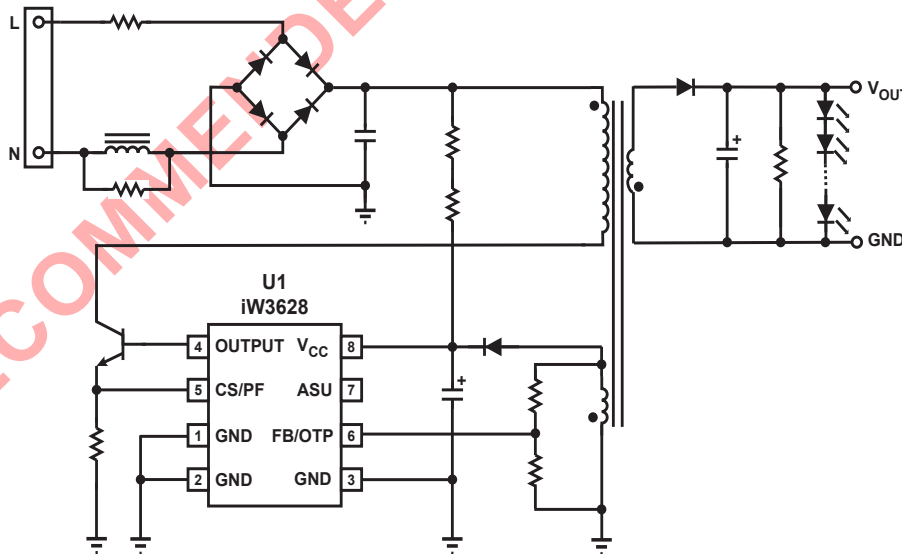

Figure 3.3: iW3628 Typical Application Circuit (Isolated Application without Using Active Start-Up Device)

Off-Line Digital Power Controller for LED Driver with High Power Factor and Low-Ripple Current

4.0 Pinout Description

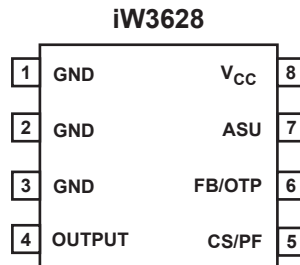

Figure 4.1: 8-Lead SOIC-8 Package

Pin #	Name	Type	Pin Description
1	GND	Ground	Ground.
2	GND	Ground	Ground.
3	GND	Ground	Ground.
4	OUTPUT	Output	Base drive for BJT.
5	CS/PF	Analog Input	Multi-function pin. Used for PF configuration at the beginning of start-up and to provide primary current sense for cycle-by-cycle peak current control and limit during normal operation.
6	FB/OTP	Analog Input	Multi-function pin. Used for OTP current derating configuration at the beginning of start-up and to provide auxiliary voltage sense for primary regulation during normal operation.
7	ASU	Output	Control signal for active start-up device (BJT or depletion mode NFET).
8	V_{CC}	Power Input	Power supply for control logic and BJT drive.

5.0 Absolute Maximum Ratings

Absolute maximum ratings are the parameter values or ranges which can cause permanent damage if exceeded.

Parameter	Symbol	Value	Units
DC supply voltage range (pin 8, $I_{CC} = 20\text{mA max}$)	V_{CC}	-0.3 to 18.0	V
Continuous DC supply current at V_{CC} pin ($V_{CC} = 15\text{V}$)	I_{CC}	20	mA
ASU output (pin 7)		-0.3 to 18.0	V
OUTPUT (pin 4)		-0.3 to 4.0	V
FB/OTP input (pin 6, $I_{FB/OTP} \leq 10\text{mA}$)		-0.7 to 4.0	V
CS/PF input (pin 5)		-0.3 to 4.0	V
Maximum junction temperature	T_{JMAX}	150	$^{\circ}\text{C}$
Operating junction temperature	T_{JOPT}	-40 to 150	$^{\circ}\text{C}$
Storage temperature	T_{STG}	-65 to 150	$^{\circ}\text{C}$
Thermal resistance junction-to-ambient	θ_{JA}	155	$^{\circ}\text{C/W}$
ESD rating per JEDEC JESD22-A114		$\pm 2,000$	V
Latch-up test per JESD78A		± 100	mA

Off-Line Digital Power Controller for LED Driver with High Power Factor and Low-Ripple Current

6.0 Physical Dimensions

8-Lead Small Outline (SOIC) Package

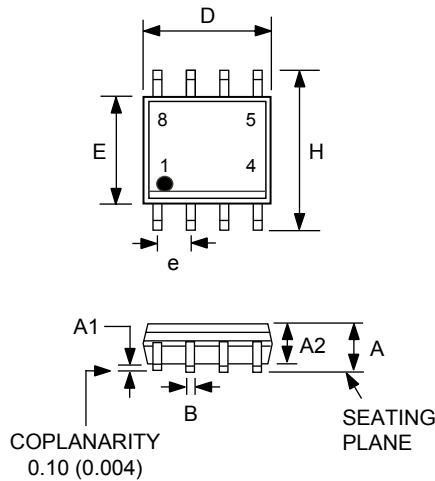

Symbol	Inches		Millimeters	
	MIN	MAX	MIN	MAX
A	0.053	0.069	1.35	1.75
A1	0.0040	0.010	0.10	0.25
A2	0.049	0.059	1.25	1.50
B	0.014	0.019	0.35	0.49
C	0.007	0.010	0.19	0.25
D	0.189	0.197	4.80	5.00
E	0.150	0.157	3.80	4.00
e	0.050 BSC		1.27 BSC	
H	0.228	0.244	5.80	6.20
h	0.10	0.020	0.25	0.50
L	0.016	0.049	0.4	1.25
α	0°	8°		

Compliant to JEDEC Standard MS12F

Controlling dimensions are in inches; millimeter dimensions are for reference only

This product is RoHS compliant and Halide free.

Soldering Temperature Resistance:

[a] Package is IPC/JEDEC Std 020D moisture sensitivity level 1

[b] Package exceeds JEDEC Std No. 22-A111 for solder immersion resistance; package can withstand 10 s immersion < 260°C

Dimension D does not include mold flash, protrusions or gate burrs. Mold flash, protrusions or gate burrs shall not exceed 0.15 mm per end. Dimension E1 does not include interlead flash or protrusion. Interlead flash or protrusion shall not exceed 0.25 mm per side.

The package top may be smaller than the package bottom. Dimensions D and E1 are determined at the outermost extremes of the plastic body exclusive of mold flash, tie bar burrs, gate burrs and interlead flash, but including any mismatch between the top and bottom of the plastic body.

7.0 Ordering Information

Part Number	Options	Package	Description
iW3628-00	Maximum driver current = 60mA	SOIC-8	Tape & Reel ¹

Note 1: Tape & Reel packing quantity is 2,500/reel. Minimum ordering quantity is 2,500.

Off-Line Digital Power Controller for LED Driver with High Power Factor and Low-Ripple Current

Disclaimer

Information in this document is believed to be accurate and reliable. However, Dialog Semiconductor does not give any representations or warranties, expressed or implied, as to the accuracy or completeness of such information. Dialog Semiconductor furthermore takes no responsibility whatsoever for the content in this document if provided by any information source outside of Dialog Semiconductor.

Dialog Semiconductor reserves the right to change without notice the information published in this document, including without limitation the specification and the design of the related semiconductor products, software and applications.

Applications, software, and semiconductor products described in this document are for illustrative purposes only. Dialog Semiconductor makes no representation or warranty that such applications, software and semiconductor products will be suitable for the specified use without further testing or modification. Unless otherwise agreed in writing, such testing or modification is the sole responsibility of the customer and Dialog Semiconductor excludes all liability in this respect.

Customer notes that nothing in this document may be construed as a license for customer to use the Dialog Semiconductor products, software and applications referred to in this document. Such license must be separately sought by customer with Dialog Semiconductor.

All use of Dialog Semiconductor products, software and applications referred to in this document are subject to Dialog Semiconductor's [Standard Terms and Conditions of Sale](#), unless otherwise stated.

© Dialog Semiconductor (UK) Ltd. All rights reserved.

RoHS compliance

Dialog Semiconductor complies to European Directive 2001/95/EC and from 2 January 2013 onwards to European Directive 2011/65/EU concerning Restriction of Hazardous Substances (RoHS/RoHS2).

Dialog Semiconductor's statement on RoHS can be found on the customer portal <https://support.diasemi.com/>. RoHS certificates from our suppliers are available on request.

Contacting Dialog Semiconductor

United Kingdom

Dialog Semiconductor (UK) Ltd
Phone: +44 1793 757700

Germany

Dialog Semiconductor GmbH
Phone: +49 7021 805-0

The Netherlands

Dialog Semiconductor B.V.
Phone: +31 73 640 88 22

Email

info_pcbg@diasemi.com

North America

Dialog Semiconductor Inc.
Phone: +1 408 845 8500

Japan

Dialog Semiconductor K. K.
Phone: +81 3 5425 4567

Taiwan

Dialog Semiconductor Taiwan
Phone: +886 8178 6222

Web site:

www.dialog-semiconductor.com

Singapore

Dialog Semiconductor Singapore
Phone: +65 64849929

Hong Kong

Dialog Semiconductor Hong Kong
Phone: +852 2607 4271

Korea

Dialog Semiconductor Korea
Phone: +82 2 3469 8200

China

Dialog Semiconductor (Shenzhen)
Phone: +86 755 2981 3669

Dialog Semiconductor (Shanghai)

Phone: +86 21 5178 2561