

## SLG46532

### ISSUE 1: Counter Incorrect Operation after the Reset Functional Block Affected: Counter

**Description:**

If the Counter Reset appears at the time very close to a rising edge of the clock signal while clock signal generation (for example OSC operation) there is a possibility that the Counter Data of the Counter is reset incorrectly and the counter end signal (HIGH pulse) may appear faster than expected. This phenomena appears more frequently the higher clock frequency is.

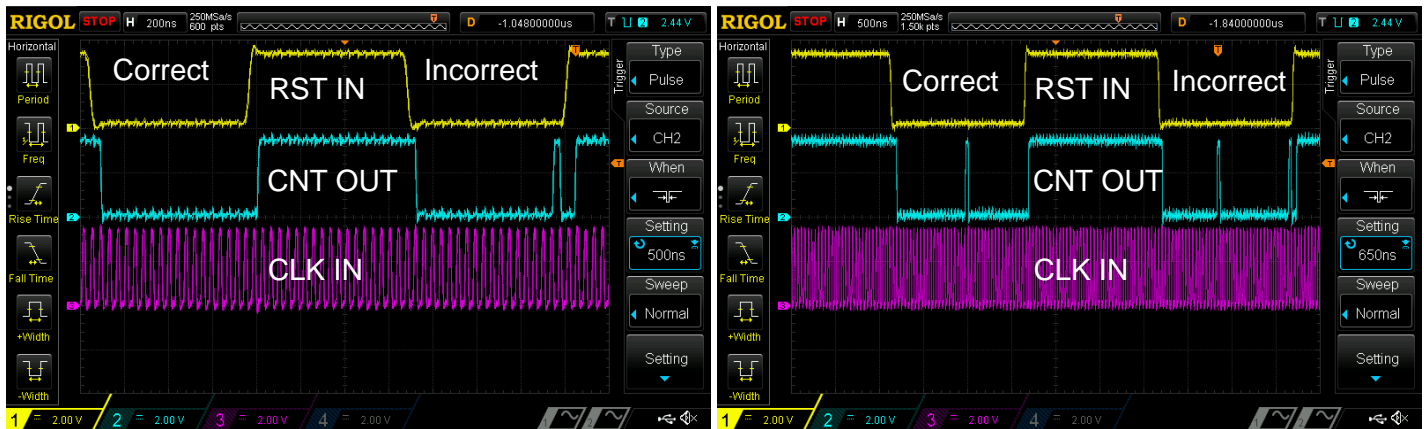
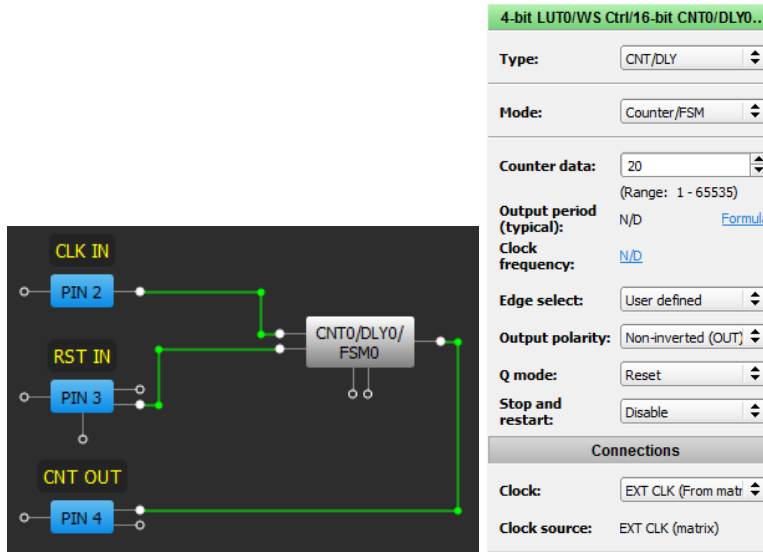

**Workaround:**

- Synchronize RESET input of the Counter with its CLK using 2 DFF cells as shown on picture below.

SLG46532

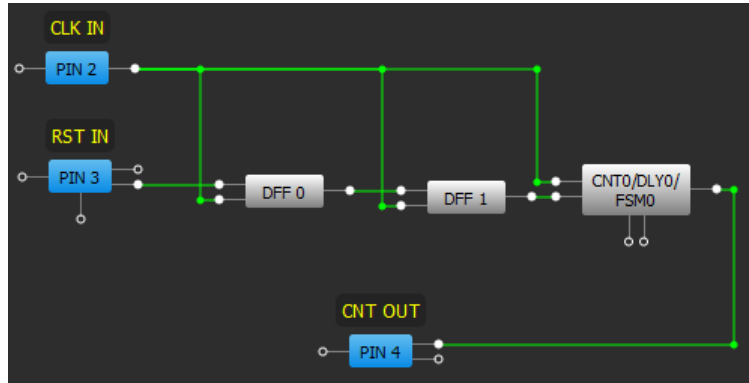

**ISSUE 2: FILTER cell does not filter out glitches**

**Functional Block Affected: FILTER**

**Description:**

If clock type high frequency input comes in, the FILTER cell may not filter out it. There are several factors like input frequency, duty cycle and LOW duration in such signal that may lead to its passing through FILTER block.

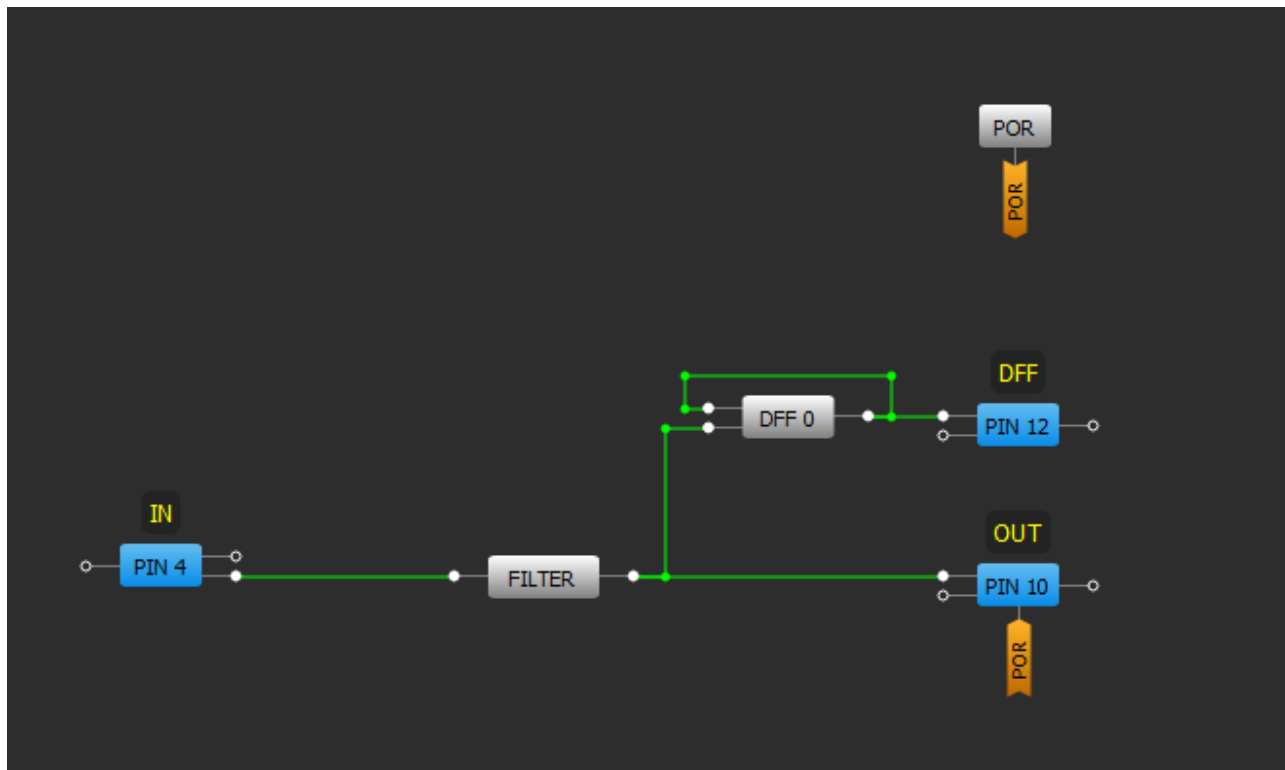

Channel 1 (yellow/top line) – PIN#4 (IN)  
 Channel 2 (light blue/2nd line) – PIN#10 (OUT)  
 Channel 3 (magenta /3rd line) – PIN#12 (DFF)

SLG46532

1. Period is 60ns. Pulse width is 10ns DC=16.7% (Correct functionality)



2. Period is 60ns. Pulse width is 20ns DC = 33.3% (Incorrect functionality)



SLG46532

3. Period is 60ns. Pulse width is 30ns DC=50% (Incorrect functionality)



4. Period is 60ns. Pulse width is 40ns DC=66.67% (Correct functionality)



SLG46532

Workaround:

Currently there is no workaround for this issue. Filter block is good at filtering short spontaneous glitches. It is intended to be used in series connection before the delay cell to avoid its latching (see issue #2).

**ISSUE 3: Incorrect I<sup>2</sup>C Reads of the 8-bit Counter Registers**  
**Functional Block Affected: CNT2/DLY2 and CNT4/DLY4**

Description:

Asynchronous interaction between the CNT/DLY clock input and the I<sup>2</sup>C latch signal (generated by an I<sup>2</sup>C read command of the CNT/DLY block's count value) can result in an incorrect I<sup>2</sup>C data read. The CNT/DLY block will count accurately, but the count value transferred into the block's I<sup>2</sup>C read register might be loaded incompletely if the I<sup>2</sup>C latch signal and the clock input occur at about the same time.

The example data capture below shows ten periodic I<sup>2</sup>C reads of CNT2/DLY2 configured to count down at about 16 clocks per read. The sixth read sample erroneously shows a value greater than that of the fifth. The seventh sample reads as if the previous I<sup>2</sup>C error never occurred - the difference from the fifth sample (176) to the seventh (143) is 33 clocks or 16 clocks + 17 clocks as expected.

- Channel 1 (yellow/top line) – PIN#2 (CNT2/DLY2 Out)
- Channel 2 (light blue/2nd line) – PIN#1 (I<sup>2</sup>C Read Triggers)
- Channel 3 (magenta /3rd line) – PIN#8 (I<sup>2</sup>C SCL)
- Channel 3 (dark blue /4th line) – PIN#9 (I<sup>2</sup>C SDA)

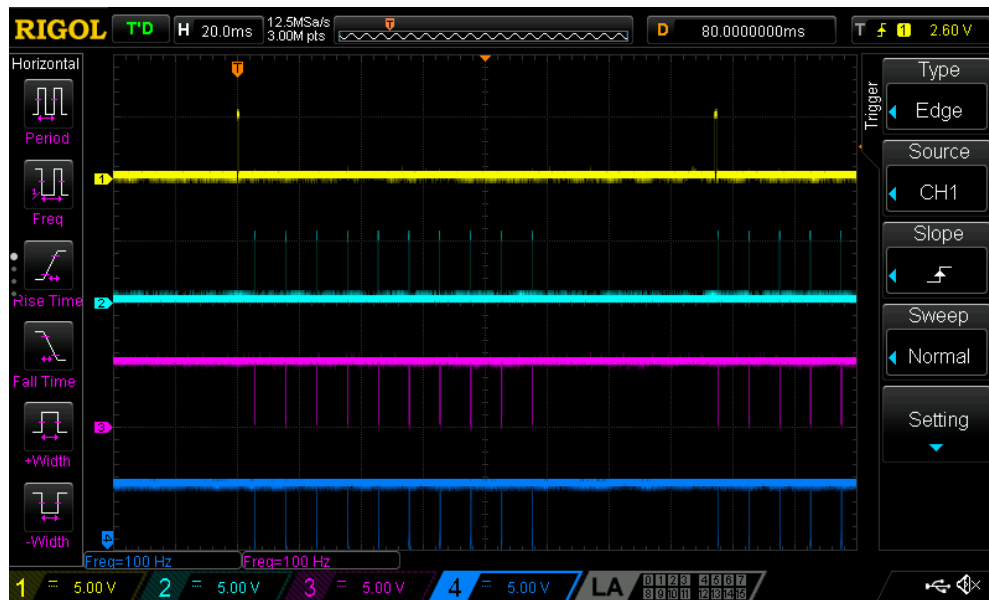

Workaround:

If the possibility of incorrect I<sup>2</sup>C data reads can't be accommodated for by external software checks, one can guarantee proper operation by stopping the CNT/DLY block's clock during I<sup>2</sup>C reads through one of the following methods: by disabling the oscillator block, by reconfiguring the CNT/DLY block's clock source, or by gating an external clock using a LUT (Look-up Table) in the signal matrix. After disabling the CNT/DLY block's clock, the count registers can be read without error. Please note that this workaround will add the I<sup>2</sup>C read and processing time to the counter's overall clock period.

The best workaround depends on the resource constraints of the application. If the oscillator block doesn't clock other logic elements within the design, a matrix output can be used to manually power down the oscillators for the I<sup>2</sup>C read. When the CNT/DLY block's clock source is routed internally from the oscillator block, I<sup>2</sup>C commands can temporarily reconfigure the CNT/DLY block's clock source registers to select "Ext. CLK. (From Matrix)." This action will disable the clock by connecting it to ground. If the CNT/DLY block is clocked from the signal matrix, a LUT can be used to gate the clock during an I<sup>2</sup>C read.

**SLG46532****ISSUE 4: Low Voltage Input does not work for Pin 8 (SCL)****Functional Block Affected: I<sup>2</sup>C****Description:**

I<sup>2</sup>C SCL low voltage input configuration is not supported.

**Workaround:**

Currently there is no workaround.

---

**ISSUE 5: ACMP additional IN- leakage current****Functional Block Affected: ACMP, PIN****Description:**

The SLG46532 has an additional leakage current through the PIN connected to the ACMP IN- input when all of the ACMPs are powered down. Typically, leakage through the PIN connected to IN- is much less than 1  $\mu$ A. But when the ACMP is powered down and voltage is applied to the PIN, the leakage current may grow up to several  $\mu$ A (depending on the VDD and voltage applied).

**Workaround:**

Currently there is no workaround for this issue.

---

## SLG46532

### Disclaimer

Information in this document is believed to be accurate and reliable. However, Dialog Semiconductor does not give any representations or warranties, expressed or implied, as to the accuracy or completeness of such information. Dialog Semiconductor furthermore takes no responsibility whatsoever for the content in this document if provided by any information source outside of Dialog Semiconductor.

Dialog Semiconductor reserves the right to change without notice the information published in this document, including without limitation the specification and design of the related semiconductor products, software and applications.

Applications, software, and semiconductor products described in this document are for illustrative purposes only. Dialog Semiconductor makes no representation or warranty that such applications, software and semiconductor products will be suitable for the specified use without further testing or modification. Unless otherwise agreed in writing, such testing or modification is the sole responsibility of the customer and Dialog Semiconductor excludes all liability in this respect.

Customer notes that nothing in this document may be construed as a license for customer to use the Dialog Semi-conductor products, software and applications referred to in this document. Such license must be separately sought by customer with Dialog Semiconductor.

All use of Dialog Semiconductor products, software and applications referred to in this document are subject to Dialog Semiconductor's [Standard Terms and Conditions of Sale](#), available on the company website ([www.dialog-semiconductor.com](http://www.dialog-semiconductor.com)) unless otherwise stated.

Dialog and the Dialog logo are trademarks of Dialog Semiconductor plc or its subsidiaries. All other product or service names are the property of their respective owners.

© 2018 Dialog Semiconductor. All rights reserved.

### RoHS Compliance

Dialog Semiconductor's suppliers certify that its products are in compliance with the requirements of Directive 2011/65/EU of the European Parliament on the restriction of the use of certain hazardous substances in electrical and electronic equipment. RoHS certificates from our suppliers are available on request.

## Contacting Dialog Semiconductor

#### United Kingdom (Headquarters)

Dialog Semiconductor (UK) LTD  
Phone: +44 1793 757700

#### Germany

Dialog Semiconductor GmbH  
Phone: +49 7021 805-0

#### The Netherlands

Dialog Semiconductor B.V.  
Phone: +31 73 640 8822

#### Email:

[enquiry@diasemi.com](mailto:enquiry@diasemi.com)

#### North America

Dialog Semiconductor Inc.  
Phone: +1 408 845 8500

#### Japan

Dialog Semiconductor K. K.  
Phone: +81 3 5769 5100

#### Taiwan

Dialog Semiconductor Taiwan  
Phone: +886 281 786 222

#### Web site:

[www.dialog-semiconductor.com](http://www.dialog-semiconductor.com)

#### Hong Kong

Dialog Semiconductor Hong Kong  
Phone: +852 2607 4271

#### Korea

Dialog Semiconductor Korea  
Phone: +82 2 3469 8200

#### China (Shenzhen)

Dialog Semiconductor China  
Phone: +86 755 2981 3669

#### China (Shanghai)

Dialog Semiconductor China  
Phone: +86 21 5424 9058