



7.3 mΩ, 9 A GreenFET 3 Load Switch with Discharge

General Description

The SLG5NT1581V is designed for load switching application. The part comes with one 9 A rated MOSFET switched on by an ON control pin. MOSFET turn on time is independently adjusted by an external capacitor.

Features

- One 9 A independent MOSFET
- Integrated VGS Charge Pump
- Internal discharge for gate and source
- User selectable ramp control by external capacitor
- Protected by thermal shutdown with current limit
- Pb-Free / RoHS Compliant
- Halogen-Free
- STDFN 14L, 1 x 3 x 0.55 mm

Pin Configuration

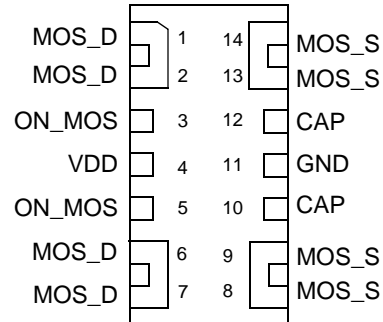

14-pin STDFN (Top View)

Target Applications

- Consumer Electronics
 - Portable: Tablets, Notebooks
 - PCs and PC peripherals
- Commercial and Industrial Electronics
 - Printers
 - Servers
 - Embedded PCs
 - Data Communications Equipment

Block Diagram

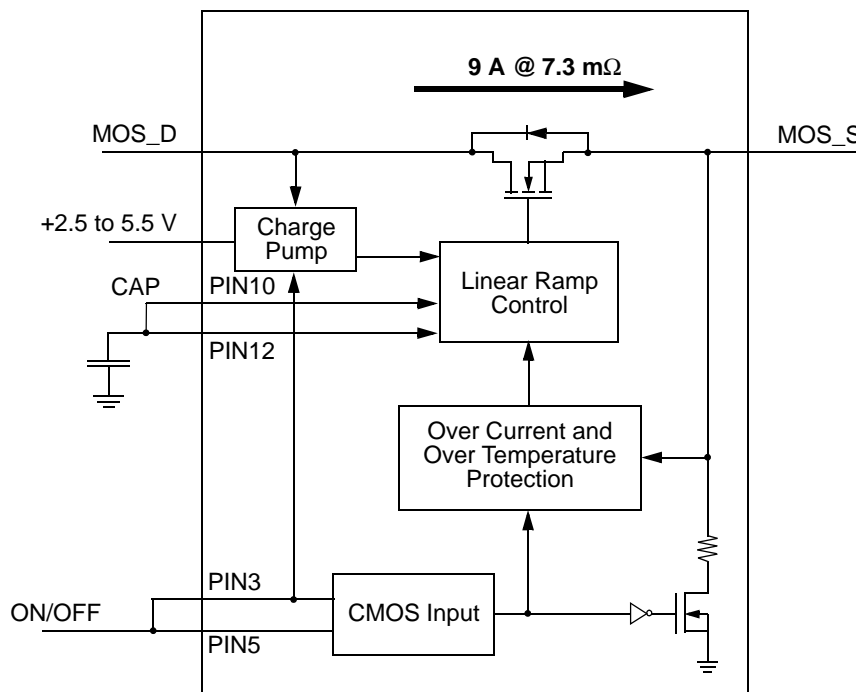



Pin Description

Pin #	Pin Name	Type	Pin Description
1	MOS_D	MOSFET	Drain of MOSFET
2	MOS_D	MOSFET	Drain of MOSFET
3	ON_MOS	Input	Turns on MOS (4 M Ω pull down resistor). Tied to Pin 5 on PCB.
4	VDD	Power	VDD Power for Load Switch Control
5	ON_MOS	Input	Turns on MOS (4 M Ω pull down resistor). Tied to Pin 3 on PCB.
6	MOS_D	MOSFET	Drain of MOSFET
7	MOS_D	MOSFET	Drain of MOSFET
8	MOS_S	MOSFET	Source of MOSFET
9	MOS_S	MOSFET	Source of MOSFET
10	CAP	Input	Sets ramp and turn on time for MOSFET. Tied to Pin 12 on PCB.
11	GND	GND	Ground
12	CAP	Input	Sets ramp and turn on time for MOSFET. Tied to Pin 10 on PCB.
13	MOS_S	MOSFET	Source of MOSFET
14	MOS_S	MOSFET	Source of MOSFET

Ordering Information

Part Number	Type	Production Flow
SLG5NT1581V	STDFN 14L	Industrial, -40 °C to 85 °C
SLG5NT1581VTR	STDFN 14L (Tape and Reel)	Industrial, -40 °C to 85 °C



Absolute Maximum Ratings

Parameter	Description	Conditions	Min.	Typ.	Max.	Unit
V _{DD}	Power Supply		--	--	6	V
T _S	Storage Temperature		-65	--	150	°C
ESD _{HBM}	ESD Protection	Human Body Model	2000	--	--	V
W _{DIS}	Package Power Dissipation		--	--	1.2	W
I _{DS_MAX}	Max Operating Current				9	A
MOSFET I _{DS_PK}	Peak Current from Drain to Source	For no more than 10 continuous seconds out of every 100 seconds	--	--	12	A

Note: Stresses greater than those listed under "Absolute Maximum Ratings" may cause permanent damage to the device. This is a stress rating only and functional operation of the device at these or any other conditions above those indicated in the operational sections of this specification is not implied. Exposure to absolute maximum rating conditions for extended periods may affect reliability.

Electrical Characteristics

T_A = -40 °C to 85 °C (unless otherwise stated)

Parameter	Description	Conditions	Min.	Typ.	Max.	Unit
V _{DD}	Power Supply Voltage		2.5	--	5.5	V
I _{DD}	Power Supply Current when OFF		--	0.1	1	μA
	Power Supply Current when ON		--	50	75	μA
R _{DS_ON}	ON Resistance	T _A = 25°C; I _{DS} = 100 mA	--	7.3	9	mΩ
		T _A = 70°C; I _{DS} = 100 mA	--	8.5	11	mΩ
		T _A = 85°C; I _{DS} = 100 mA		8	11.5	mΩ
MOSFET I _{DS}	Current from Drain to Source	Continuous	--	--	9	A
V _{MOS_D}	Drain Voltage		1.0	5.0	V _{DD}	V
T _{ON_Delay}	ON Delay Time	50% ON to Ramp Begin	--	300	500	μs
T _{Total_ON}	Total Turn On Time	50% ON to 90% V _S	Configurable ¹			ms
		Example: CAP (Pin 10 & 12) share a single 4nF capacitor, V _{DD} = V _D = 5 V, C _{LOAD} = 10 μF, R _{LOAD} = 20 Ω	--	1.1	--	ms
V _{S(SR)}	Slew Rate	10% V _S to 90% V _S	Configurable ¹			V/ms
		Example: CAP (Pin 10 & 12) share a single 4nF capacitor, V _{DD} = V _D = 5 V, C _{LOAD} = 10 μF, R _{LOAD} = 20 Ω	--	6.0	--	V/ms
C _{LOAD}	Output Load Capacitance	C _{LOAD} connected from MOS_S to GND	--	--	1000	μF
R _{DIS}	Discharge Resistance		100	210	300	Ω
ON_V _{IH}	High Input Voltage on ON pin		0.85	--	V _{DD}	V
ON_V _{IL}	Low Input Voltage on ON pin		-0.3	0	0.3	V
I _{LIMIT}	Active Current Limit	MOSFET will automatically limit current when V _S > 250 mV	--	12.0	--	A
	Short Circuit Current Limit	MOSFET will automatically limit current when V _S < 250 mV	--	0.5	--	A
THERM _{ON}	Thermal shutoff turn-on temperature		--	125	--	°C
THERM _{OFF}	Thermal shutoff turn-off temperature		--	100	--	°C
THERM _{TIME}	Thermal shutoff time		--	--	1	ms



$T_A = -40\text{ }^\circ\text{C}$ to $85\text{ }^\circ\text{C}$ (unless otherwise stated)

Parameter	Description	Conditions	Min.	Typ.	Max.	Unit
$T_{\text{OFF_Delay}}$	OFF Delay Time	50% ON to V_S Fall, $V_{\text{DD}} = V_D = 5\text{ V}$	--	--	15	μs

Notes:

1. Refer to table for configuration details.

$T_{\text{Total_ON}}$, $T_{\text{ON_Delay}}$ and Slew Rate Measurement

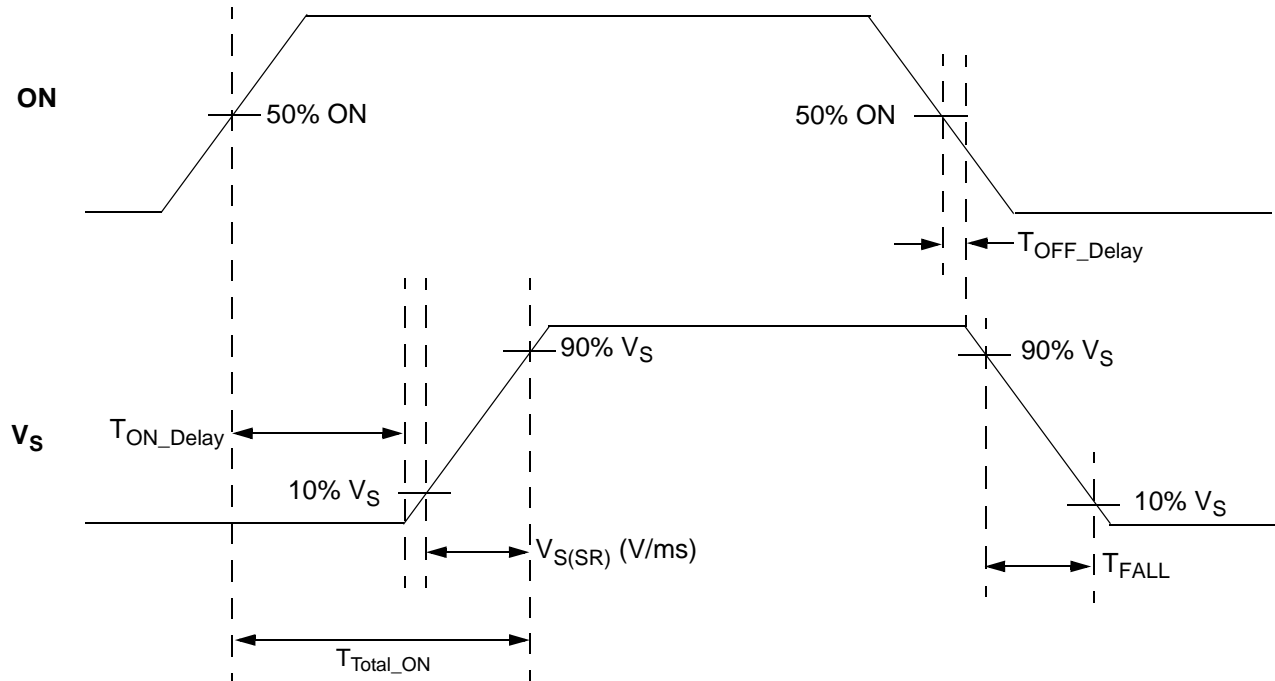



Slew Rate vs. CAP, V_{MOS_D} , and V_{DD}

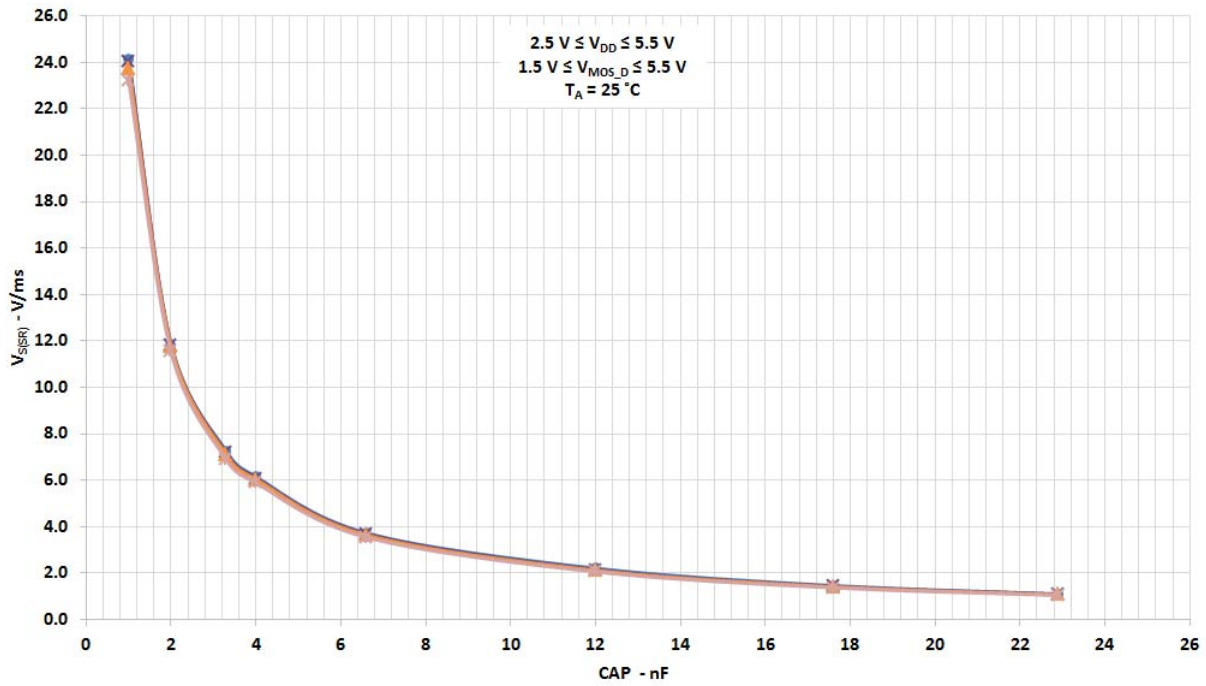

T_{Total_ON} vs. CAP, V_{MOS_D} , and V_{DD}

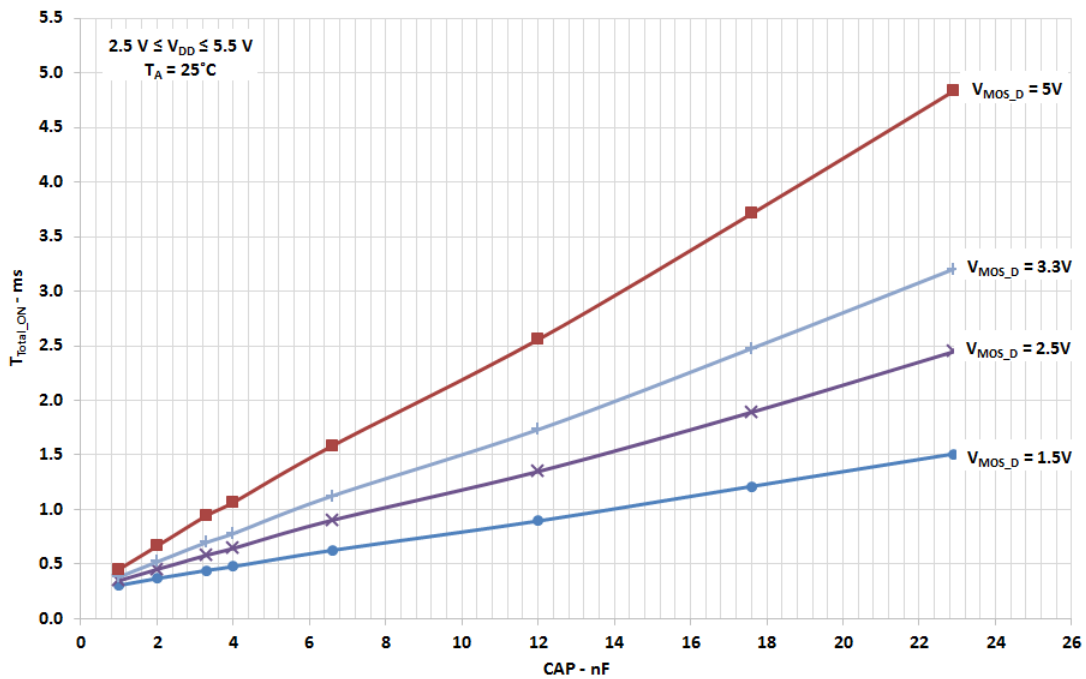



Package Top Marking System Definition





Package Drawing and Dimensions

14 Lead STDFN Package 1 mm x 3 mm (Fused Lead)

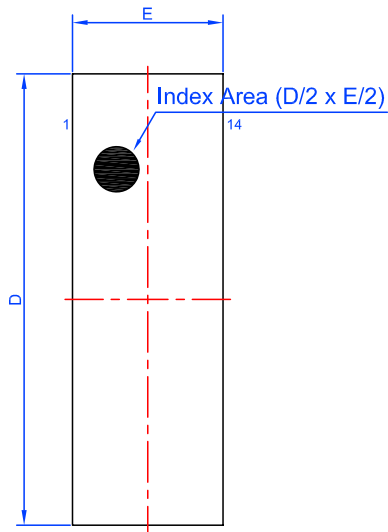

Top View

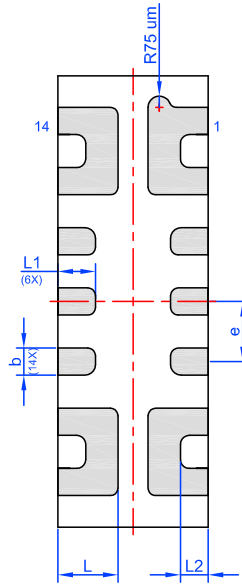

BTM View

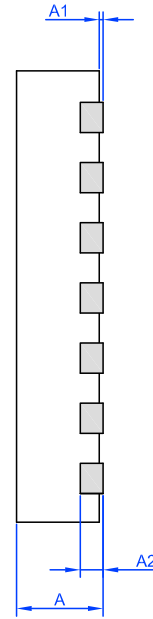

SIDE View

Unit: mm

Symbol	Min	Nom.	Max	Symbol	Min	Nom.	Max
A	0.50	0.55	0.60	D	2.95	3.00	3.05
A1	0.005	-	0.050	E	0.95	1.00	1.05
A2	0.10	0.15	0.20	L	0.35	0.40	0.45
b	0.13	0.18	0.23	L1	0.20	0.25	0.30
e	0.40 BSC			L2	0.06	0.11	0.16



Tape and Reel Specifications

Package Type	# of Pins	Nominal Package Size	Units per Reel	Max Units per Box	Reel & Hub Size (mm)	Trailer A		Leader B		Pocket Tape(mm)	
						Pockets	Length (mm)	Pockets	Length (mm)	Width	Pitch
14STDFN	14	1x3x0.55mm	3000	3000	178/60	42	168	42	168	8	4

Tape and Reel Drawing

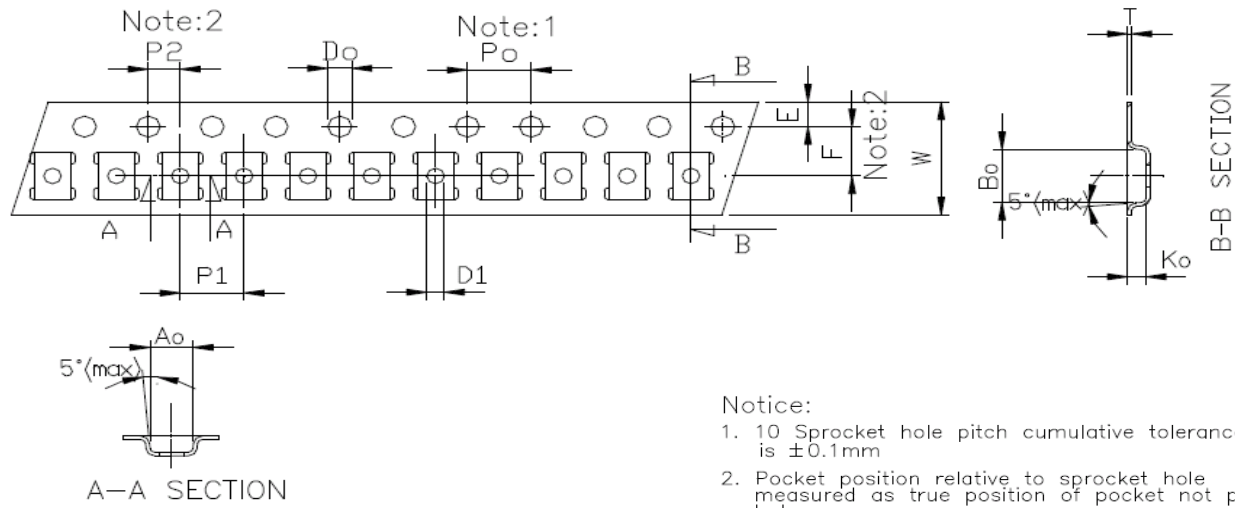

Notice:

1. 10 Sprocket hole pitch cumulative tolerance is $\pm 0.1\text{mm}$
2. Pocket position relative to sprocket hole measured as true position of pocket not pocket hole.
3. Ao & Bo measured on a plane 0.3mm above the bottom of the pocket to top surface of the carrier.
4. Ko measured from a plane on the inside bottom of the pocket to the top surface of the carrier.
5. Carrier camber shall be not than 1mm per 100mm through a length of 250mm.

Symbol	Dimension (mm)	Symbol	Dimension (mm)
Ao	2.25 ± 0.10	P2	2.0 ± 0.05
Bo	3.30 ± 0.10	Do	1.55 ± 0.05
Ko	1.20 ± 0.10	D1	1.10 ± 0.10
Po	4.0 ± 0.10	E	1.75 ± 0.10
P1	4.0 ± 0.10	F	3.50 ± 0.05
W	8.0 ± 0.20	T	0.25 ± 0.05



Revision History

Date	Version	Change
4/13/2018	1.03	Fixed typo in Block Diagram Fixed typo in Abs Max Table Clean up EC Table Parameters and Conditions Updated Charts