



The SLG74803 is a member of Silego's PCI Express Clock Buffer Family.

Recommended Application:

PCI Express Gen1, Gen2, and Gen3 Reference Clock Buffer

Output Features:

- 8 - 0.7V current-mode differential output pairs
- Supports zero delay buffer mode and fanout mode
- Bandwidth programming available

Key Specifications:

- Outputs cycle-cycle jitter < 50ps
- Outputs skew: 50ps
- Phase jitter: PCIe Gen1 < 86ps peak to peak
- Phase jitter: PCIe Gen2 < 3.1ps rms
- Phase jitter: PCIe Gen3 < 1.0ps rms

Features/Benefits:

- Spread spectrum modulation tolerant, 0 to -0.5% down spread and +/- 0.25% center spread
- Supports undriven differential outputs in PD# and SRC_STOP# modes for power management.

Pin Configuration

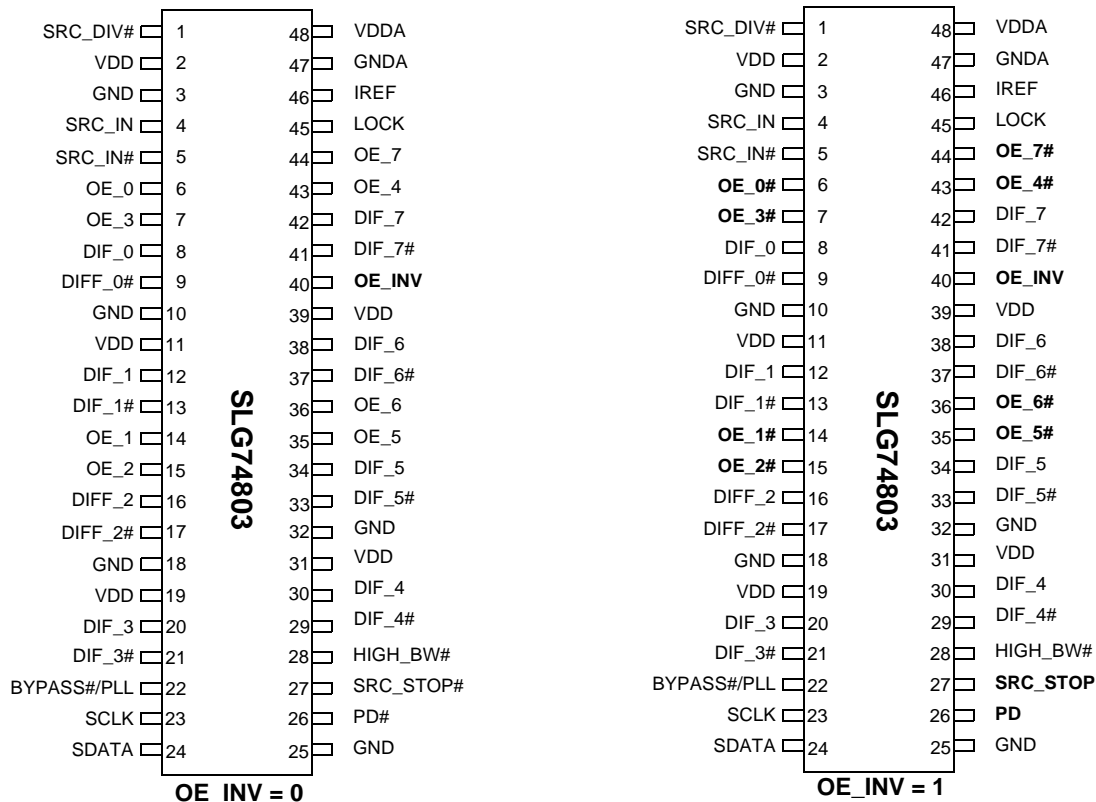

48-pin SSOP & TSSOP

Other brands and names may be claimed as the property of others



Pin Description for OE_INV = 0

Pin #	Name	Type	Description
1	SRC_DIV#	IN	Active low Input for determining SRC output frequency SRC or SRC/2 0 = SRC/2, 1 = SRC
2	VDD	PWR	Power supply, nominal 3.3V
3	GND	PWR	Ground pin.
4	SRC_IN	IN	0.7V Differential SRC TRUE input
5	SRC_IN#	IN	0.7V Differential SRC COMPLEMENTARY input
6	OE_0	IN	Active high input for enabling outputs. 0 = tri-state outputs, 1 = enable outputs
7	OE_3	IN	Active high input for enabling outputs 0 = tri-state outputs, 1 = enable outputs
8	DIF_0	OUT	0.7V differential true clock outputs
9	DIF_0#	OUT	0.7V differential complement clock outputs
10	GND	PWR	Ground pin
11	VDD	PWR	Power supply, nominal 3.3V
12	DIF_1	OUT	0.7V differential true clock outputs
13	DIF_1#	OUT	0.7V differential complement clock outputs
14	OE_1	IN	Active high input for enabling outputs. 0=tri-state outputs, 1=enable outputs
15	OE_2	IN	Active high input for enabling outputs. 0=tri-state outputs, 1=enable outputs
16	DIF_2	OUT	0.7V differential true clock outputs
17	DIF_2#	OUT	0.7V differential complement clock outputs
18	GND	PWR	Ground pin
19	VDD	PWR	Power supply, nominal 3.3V
20	DIF_3	OUT	0.7V differential true clock outputs
21	DIF_3#	OUT	0.7V differential complement clock outputs
22	BYPASS#/PLL	IN	Input to select Bypass(fan-out) or PLL (ZDB) mode 0 = Bypass mode, 1 = PLL mode
23	SCLK	IN	Clock pin of SMBus circuitry 5V tolerant
24	SDATA	I/O	Data pin for SMBus circuitry 5V tolerant
25	GND	PWR	Ground pin
26	PD#	IN	Asynchronous active low input pin, with 120Kohm internal pull-up resistor, used to power down the device. The internal clocks are disabled and the VCO and the crystal are stopped
27	SRC_STOP	IN	Active low input to stop SRC outputs
28	HIGH_BW#	IN	3.3V input for selecting PLL Band Width 0 = High, 1= Low
29	DIF_4#	OUT	0.7V differential complement clock outputs
30	DIF_4	OUT	0.7V differential true clock outputs
31	VDD	PWR	Power supply, nominal 3.3V



Pin Description for OE_INV = 0 (continued)

Pin #	Name	Type	Description
32	GND	PWR	Ground pin.
33	DIF_5#	OUT	0.7V differential complement clock outputs
34	DIF_5	OUT	0.7V differential clock outputs
35	OE_5	IN	Active high inputs for enabling outputs 0 = tri-state outputs, 1 = enable outputs
36	OE_6	IN	Active high input for enabling outputs. 0 = tri-state outputs, 1 = enable outputs
37	DIF_6#	OUT	0.7V differential complement clock outputs
38	DIF_6	OUT	0.7V differential true clock outputs
39	VDD	PWR	Power supply, nominal 3.3V
40	OE_INV	IN	This latched input selects the polarity of the OE pins. 0 = OE pins active high, 1 = OE pins active low (OE#)
41	DIF_7#	OUT	0.7V differential complement clock outputs
42	DIF_7	OUT	0.7V differential true clock outputs
43	OE_4	IN	Active high input for enabling outputs. 0 = tri-state outputs, 1 = enable outputs
44	OE_7	IN	Active high input for enabling outputs. 0 = tri-state outputs, 1 = enable outputs
45	LOCK	OUT	3.3V output indicating PLL Lock Status. This pin goes high when lock is achieved
46	IREF	IN	This pin establishes the reference current for the differential current-mode output pairs. This pin requires a fixed precision resistor tied to ground in order to establish the appropriate current. 475 ohms is the standard value.
47	GND_A	PWR	Ground pin for the PLL core.
48	VDD_A	PWR	3.3V power for the PLL core.



Pin Description for OE_INV = 1

Pin #	Name	Type	Description
1	SRC_DIV#	IN	Active low Input for determining SRC output frequency SRC or SRC/2 0 = SRC/2, 1 = SRC
2	VDD	PWR	Power supply, nominal 3.3V
3	GND	PWR	Ground pin.
4	SRC_IN	IN	0.7V Differential SRC TRUE input
5	SRC_IN#	IN	0.7V Differential SRC COMPLEMENTARY input
6	OE_0#	IN	Active low input for enabling DIF pair 0 1 = tri-state outputs, 0 = enable outputs
7	OE_3#	IN	Active low input for enabling DIF pair 3 1 = tri-state outputs, 0 = enable outputs
8	DIF_0	OUT	0.7V differential true clock outputs
9	DIF_0#	OUT	0.7V differential complement clock outputs
10	GND	PWR	Ground pin
11	VDD	PWR	Power supply, nominal 3.3V
12	DIF_1	OUT	0.7V differential true clock outputs
13	DIF_1#	OUT	0.7V differential complement clock outputs
14	OE_1#	IN	Active low input for enabling DIF pair 1. 1=tri-state outputs, 0=enable outputs
15	OE_2#	IN	Active low input for enabling DIF pair 2. 1=tri-state outputs, 0=enable outputs
16	DIF_2	OUT	0.7V differential true clock outputs
17	DIF_2#	OUT	0.7V differential complement clock outputs
18	GND	PWR	Ground pin
19	VDD	PWR	Power supply, nominal 3.3V
20	DIF_3	OUT	0.7V differential true clock outputs
21	DIF_3#	OUT	0.7V differential complement clock outputs
22	BYPASS#/PLL	IN	Input to select Bypass(fan-out) or PLL (ZDB) mode 0 = Bypass mode, 1 = PLL mode
23	SCLK	IN	Clock pin of SMBus circuitry 5V tolerant
24	SDATA	I/O	Data pin for SMBus circuitry 5V tolerant
25	GND	PWR	Ground pin
26	PD	IN	Asynchronous active high input pin used to power down the device. The internal clocks are disabled and the VCO is stopped.
27	SRC_STOP	IN	Active high input to stop SRC outputs
28	HIGH_BW#	IN	3.3V input for selecting PLL Bandwidth 0 = High, 1= Low
29	DIF_4#	OUT	0.7V differential complement clock outputs
30	DIF_4	OUT	0.7V differential true clock outputs
31	VDD	PWR	Power supply, nominal 3.3V
32	GND	PWR	Ground pin.
33	DIF_5#	OUT	0.7V differential complement clock outputs
34	DIF_5	OUT	0.7V differential clock outputs
35	OE_5#	IN	Active low input for enabling DIF pair 5. 1 = tri-state outputs, 0 = enable outputs



Pin #	Name	Type	Description
36	OE_6#	IN	Active low input for enabling DIF pair 6. 1= tri-state outputs, 0= enable outputs
37	DIF_6#	OUT	0.7V differential complement clock outputs
38	DIF_6	OUT	0.7V differential true clock outputs
39	VDD	PWR	Power supply, nominal 3.3V
40	OE_INV	IN	This latched input selects the polarity of the OE pins. 0 = OE pins active high, 1 = OE pins active low (OE#)
41	DIF_7#	OUT	0.7V differential complement clock outputs
42	DIF_7	OUT	0.7V differential true clock outputs
43	OE_4#	IN	Active low input for enabling DIF pair 4. 1= tri-state outputs, 0 = enable outputs
44	OE_7#	IN	Active low input for enabling DIF pair 7. 1= tri-state outputs, 0 = enable outputs
45	LOCK	OUT	3.3V output indicating PLL Lock Status. This pin goes high when lock is achieved
46	IREF	IN	This pin establishes the reference current for the differential current-mode output pairs. This pin requires a fixed precision resistor tied to ground in order to establish the appropriate current. 475 ohms is the standard value.
47	GND_A	PWR	Ground pin for the PLL core.
48	VDDA	PWR	3.3V power for the PLL core.

continued



General Description

The SLG74803 follows the Intel DB800 Differential Buffer Specification v2.0. This buffer provides eight PCI-Express SRC clocks. The SLG74803 is driven by a differential input pair from a CK409/CK410 main clock generator. It provides outputs meeting tight cycle-to-cycle jitter (50ps) and output-to-output skew (50ps) requirements.

Block Diagram

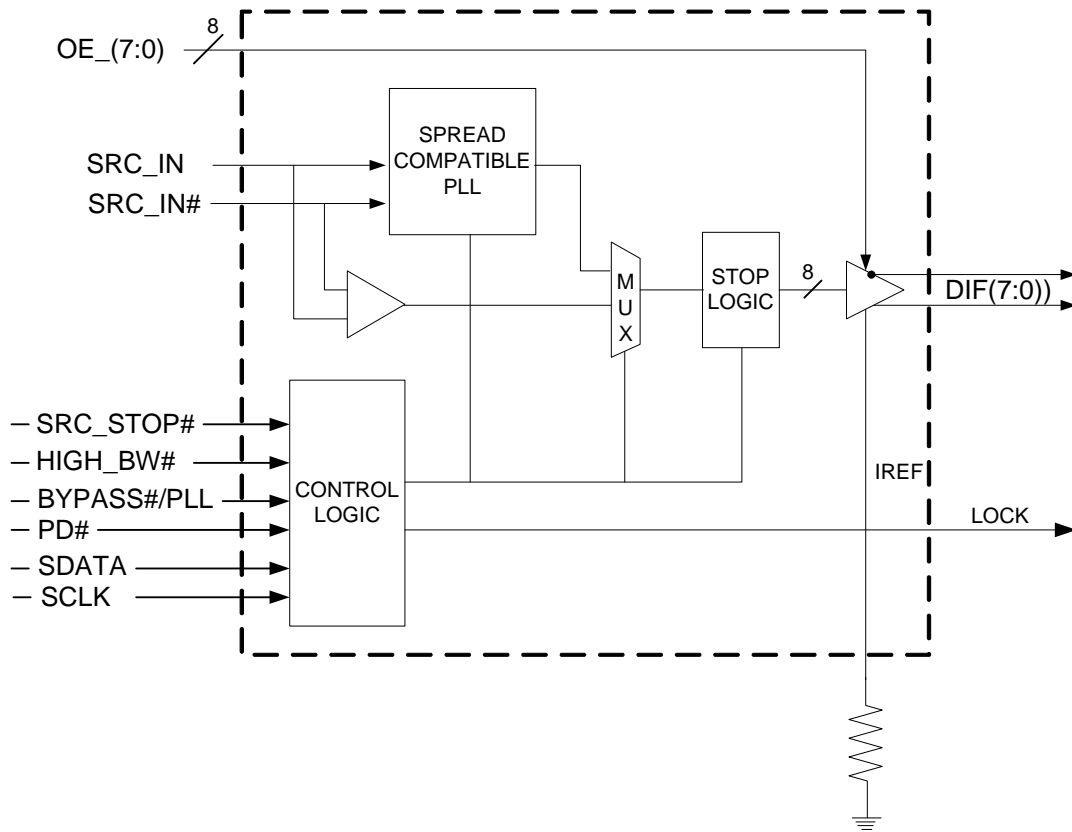

Note: Polarities shown for OE_INV = 0.

**Absolute Max**

Symbol	Parameter	Min	Max	Units
VDD_A	3.3V Core Supply Voltage		4.6	V
VDD_In	3.3V Logic Supply Voltage		4.6	V
V _{IL}	Input Low Voltage	GND-0.5		V
V _{IH}	Input High Voltage		V _{DD} +0.5V	V
T _S	Storage Temperature	-65	150	°C
T _{ambient}	Ambient Operating Temp	0	70	°C
T _{ambient}	Ambient Operating Temp (ordering option K)	0	85	°C
T _{case}	Case Temperature		115	°C
ESD protection	Input ESD protection human body model	2000		V

Electrical Characteristics - Input/Supply/Common Output ParametersT_A = 0 to (70°C or 85°C); Supply Voltage V_{DD} = 3.3V +/-5%

Parameter	Symbol	Conditions	Min	Typ	Max	Units	Notes
Input High Voltage	V _{IH}	3.3 V +/-5%	2		V _{DD} + 0.3	V	
Input Low Voltage	V _{IL}	3.3V +/-5%	GND - 0.3		0.8	V	
Input High Current	I _{IH}	V _{IN} = V _{DD}	-5		5	uA	
Input Low Current	I _{IL1}	V _{IN} = 0V; Inputs with no pull-up resistors	-5			uA	
	I _{IL2}	V _{IN} = 0V; Inputs with pull-up resistors	-200			uA	
Operating Supply Current	I _{DD3,3OP}	Full Active, C _L = Full load;			200	mA	
Powerdown Current		All differential pairs driven			70	mA	
	I _{DD3,3PD}	All differential pairs tri-stated			4	mA	
Input Frequency ³	F _i	V _{DD} = 3.3V	50		110	MHz	3
	F _{iBYPASS}	Bypass Mode	50		400	MHz	1
Pin Inductance ¹	L _{pin}				7	nH	1
Input Capacitance ¹	C _{IN}	Logic Inputs	1.5		5	pF	1
	C _{OUT}	Output pin capacitance			6	pF	1
PLL Bandwidth	BW	PLL Bandwidth when PLL_BW#=0	2	3		MHz	1
		PLL Bandwidth when PLL_BW#=1	0.7	1	1.4	MHz	1
CLK Stabilization ^{1,2}	T _{STAB}	From V _{DD} Power-Up and after input clock stabilization or deassertion of PD# to 1st clock			1	ms	1,2
Modulation Frequency		Triangular Modulation	30		33	kHz	1
Tdrive_SRC_STOP#		DIF output enable after SRC_Stop# de-assertion			15	ns	1,3
Tdrive_PD#		DIF output enable after PD# de-assertion			300	us	1,3



Parameter	Symbol	Conditions	Min	Typ	Max	Units	Notes
Tfall		Fall time of PD# and SRC_STOP#			5	ns	1
Trise		Rise time of PD# and SRC_STOP#			5	ns	2



Electrical Characteristics - DIF 0.7V Current Mode Differential Pair

$T_A = 0$ to $(70^\circ\text{C}$ or $85^\circ\text{C})$; $V_{DD} = 3.3\text{V} \pm 5\%$, $C_L = 2\text{pF}$, $R_S = 33.2\Omega$, $R_P = 49.9\Omega$, $I_{REF} = 475\Omega$

Parameter	Symbol	Conditions	Min	Typ	Max	Units	Notes
Current Source Output Impedance	Z_O^1	$V_O = V_X$	3000			Ω	1
Voltage High	VHigh	Statistical measurement on single ended signal using oscilloscope math function.	660		850	mV	1,3
Voltage Low	VLow		-150		150		1,3
Max Voltage	Vovs	Measurement on single ended signal using absolute value			1150	mV	1
Min Voltage	Vuds		-300				1
Crossing Voltage (abs)	Vcross(abs)		250		550	mB	1
Crossing Voltage (var)	d-Vcross	Variation of crossing over all edges			140	mV	1
Long Accuracy	ppm	see Tperiod min-max values			0	ppm	1,2
Rise Time	t_r	$V_{OL} = 0.175\text{V}$, $V_{OH} = 0.525\text{V}$	175		700	ps	1
Fall Time	t_f	$V_{OH} = 0.525\text{V}$ $V_{OL} = 0.175\text{V}$	175		700	ps	1
Rise Time Variation	d- t_r				125	ps	1
Fall Time Variation	d- t_f				125	ps	1
Duty Cycle	d_{13}	Measurement from differential waveform	45	50	55	%	1
Skew	t_{sk3}	$V_T = 50\%$			50	ps	1
		PLL Mode		40	50	ps	1,5
Jitter, Cycle to Cycle	$t_{j\text{cyc-cyc}}$	BYPASS mode as additive jitter		15	50	ps	1,4,5
Jitter, Phase	$t_{j\text{phasebypass}}$	PCIe Gen 1 specs (pk to pk value)		30	86	ps	1,4
		PCIe Gen 2 specs (rms value)		2.6	3.1	ps	1,4
	$t_{j\text{phasePLL}}$	PCIe Gen 1 specs (pk to pk value)		40	86	ps	1,6
		PCIe Gen 2 specs (rms value)		2.8	3.1	ps	1,6
		PCIe Gen 3 specs (rms value)		0.7	1.0	ps	1,6,7

¹ Guaranteed by design and characterization, not 100% tested in production.

² All Long Term Accuracy and Clock Period specifications are guaranteed with the assumption that the input clock complies with CK409/CK410/CK505 accuracy requirements.

³ $I_{REF} = V_{DD}/(3 \times R_R)$. For $R_R = 475\Omega$ (1%), $I_{REF} = 2.32\text{mA}$. $I_{OH} = 6 \times I_{REF}$ and $V_{OH} = 0.7\text{V}$ @ $Z_O = 50\Omega$

⁴ Applies to Bypass Mode Only

⁵ Measured from differential waveform

⁶ Device driven by HP81134A generator

⁷ PCIe* Gen3 filter characteristics are subject to final ratification by PCISIG. Please check the PCI* SIG for the latest specification.



SRC Reference Clock			
Common Recommendations for Differential Routing	Dimension or Value	Unit	Figure
L1 length, Route as non-coupled 50 ohm trace	0.5 max	inch	2, 3
L2 length, Route as non-coupled 50 ohm trace	0.2 max	inch	2, 3
L3 length, Route as non-coupled 50 ohm trace	0.2 max	inch	2, 3
R_s	33	ohm	2, 3
R_t	49.9	ohm	2, 3

Down Device Differential Routing	Dimension or Value	Unit	Figure
L4 length, Route as coupled microstrip 100 ohm differential trace	2 min to 16 max	inch	2
L4 length, Route as coupled stripline 100 ohm differential trace	1.8 min to 14.4 max	inch	2

Differential Routing to PCI Express Connector	Dimension or Value	Unit	Figure
L4 length, Route as coupled microstrip 100 ohm	0.25 to 14 max	inch	3
L4 length, Route as coupled stripline 100 ohm	0.225 min to 12.6 max	inch	3

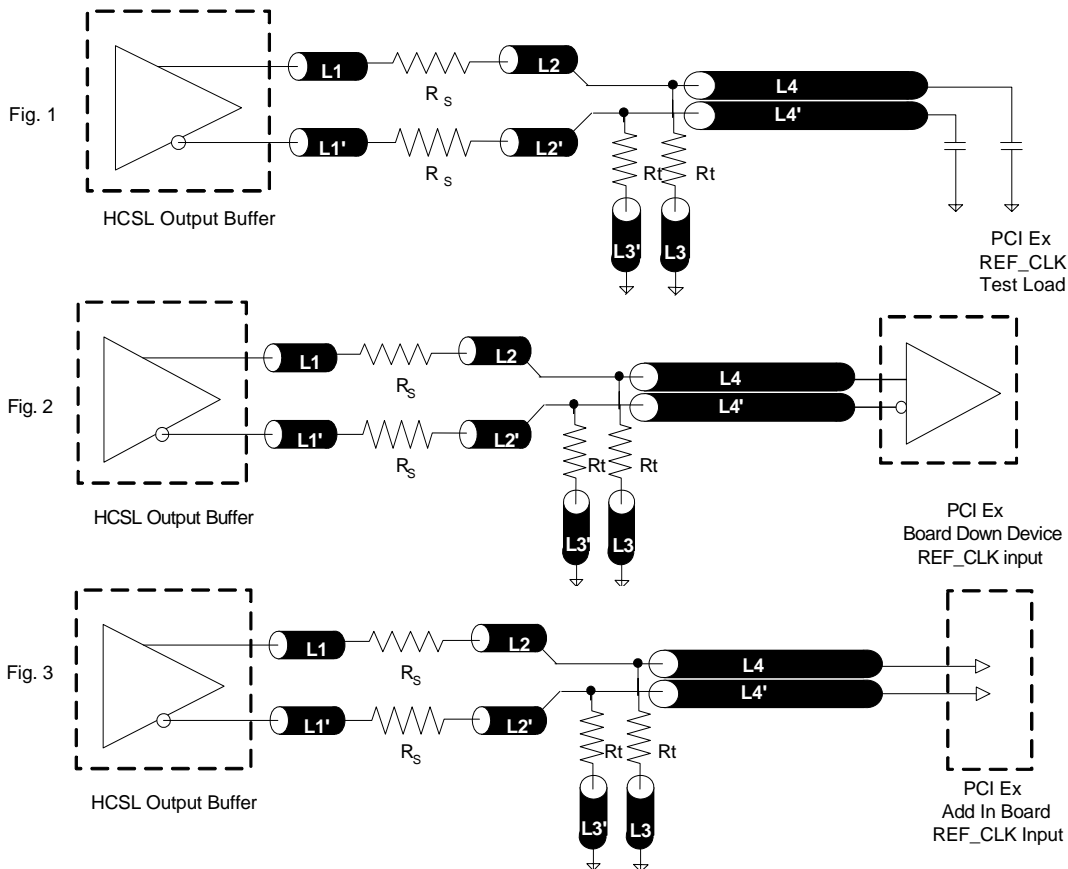



General SMBus serial interface information for the SLG74803

How to Write:

- Controller (host) sends a start bit.
- Controller (host) sends the write address DC_(H)
- Silego clock will **acknowledge**
- Controller (host) sends the beginning byte location = N
- Silego clock will **acknowledge**
- Controller (host) sends the data byte count = X
- Silego clock will **acknowledge**
- Controller (host) starts sending **Byte N through Byte N + X - 1**
(see Note 2)
- Silego clock will **acknowledge** each byte **one at a time**
- Controller (host) sends a Stop bit

How to Read:

- Controller (host) will send start bit.
- Controller (host) sends the write address DC_(H)
- Silego clock will **acknowledge**
- Controller (host) sends the beginning byte location = N
- Silego clock will **acknowledge**
- Controller (host) will send a separate start bit.
- Controller (host) sends the read address DD_(H)
- Silego clock will **acknowledge**
- Silego clock will send the data byte count = X
- Silego clock sends **Byte N + X - 1**
- Silego clock sends **Byte 0 through byte X (if X_(H) was written to byte 8).**
- Controller (host) will need to acknowledge each byte
- Controller (host) will send a not acknowledge bit
- Controller (host) will send a stop bit

Index Block Write Operation		
Controller (Host)		Silego(Slave/Receiver)
T	Start Bit	
Slave Address DC _(H)		
WR	Write	
		Ack
Beginning Byte = N		
		Ack
Data Byte Count = X		
		Ack
Beginning Byte N	X Byte	
		Ack
O		O
O		O
O		O
Byte N + X - 1		
		Ack
P	Stop Bit	

Index Block Read Operation		
Controller (Host)		Silego (Slave/Receiver)
T	Start Bit	
Slave Address DC _(H)		
WR	Write	
		Ack
Beginning Byte = N		
		Ack
RT	Repeat Start	
Slave Address DD _(H)		
RD	Read	
		Ack
		Data Byte Count = X
Ack		
		Beginning Byte N
Ack		
		O
O		O
O		O
		Byte N + X - 1
N	Not Ack	
P	Stop Bit	



SMBus Table: Frequency Select Register, READ/WRITE ADDRESS (DC/DD)

Byte 0	Pin #	Name	Control Function	Type	0	1	PWD
Bit 7	-	PD_Mode	PD# drive mode	RW	driven	Hi-Z	0
Bit 6	-	STOP_Mode	SRC_Stop# drive mode	RW	driven	Hi-Z	0
Bit 5	-	PD_Polarity	X	RW	low	high	0
Bit 4	-	Reserved	Reserved	RW	Reserved		X
Bit 3	-	Reserved	Reserved	RW	Reserved		X
Bit 2	-	PLL_BW#	Select PLL BW	RW	High BW	Low BW	1
Bit 1	-	BYPASS#	BYPASS#/PLL	RW	fan-out	ZDB	1
Bit 0	-	SRC_DIV#	SRC Divide by 2 Select	RW	x/2	1x	1

SMBus Table:Output Control Register

Byte 1	Pin #	Name	Control Function	Type	0	1	PWD
Bit 7	42,41	DIF_7	Output Control	RW	Disable	Enable	1
Bit 6	38,37	DIF_6	Output Control	RW	Disable	Enable	1
Bit 5	34,33	DIF_5	Output Control	RW	Disable	Enable	1
Bit 4	30,29	DIF_4	Output Control	RW	Disable	Enable	1
Bit 3	20,21	DIF_3	Output Control	RW	Disable	Enable	1
Bit 2	16,17	DIF_2	Output Control	RW	Disable	Enable	1
Bit 1	12,13	DIF_1	Output Control	RW	Disable	Enable	1
Bit 0	8,9	DIF_0	Output Control	RW	Disable	Enable	1

SMBus Table:Output Control Register

Byte 2	Pin #	Name	Control Function	Type	0	1	PWD
Bit 7	42,41	DIF_7	Output Control	RW	Free-run	Stoppable	0
Bit 6	38,37	DIF_6	Output Control	RW	Free-run	Stoppable	0
Bit 5	34,33	DIF_5	Output Control	RW	Free-run	Stoppable	0
Bit 4	30,29	DIF_4	Output Control	RW	Free-run	Stoppable	0
Bit 3	20,21	DIF_3	Output Control	RW	Free-run	Stoppable	0
Bit 2	16,17	DIF_2	Output Control	RW	Free-run	Stoppable	0
Bit 1	12,13	DIF_1	Output Control	RW	Free-run	Stoppable	0
Bit 0	8,9	DIF_0	Output Control	RW	Free-run	Stoppable	0



SMBus Table: Output Control Register

Byte 3		Pin #	Name	Control Function	Type	0	1	PWD
Bit 7				Reserved	RW	Reserved		X
Bit 6				Reserved	RW	Reserved		X
Bit 5				Reserved	RW	Reserved		X
Bit 4				Reserved	RW	Reserved		X
Bit 3				Reserved	RW	Reserved		X
Bit 2				Reserved	RW	Reserved		X
Bit 1				Reserved	RW	Reserved		X
Bit 0				Reserved	RW	Reserved		X

SMBus Table: Vendor & Revision ID Register

Byte 4		Pin #	Name	Control Function	Type	0	1	PWD
Bit 7		-	RID3	REVISION ID	R	-	-	0
Bit 6		-	RID2		R	-	-	0
Bit 5		-	RID1		R	-	-	0
Bit 4		-	RID0		R	-	-	0
Bit 3		-	VID3	VENDOR ID	R	-	-	0
Bit 2		-	VID2		R	-	-	1
Bit 1		-	VID1		R	-	-	1
Bit 0		-	VID0		R	-	-	0

SMBus Table: DEVICE ID

Byte 5		Pin #	Name	Control Function	Type	0	1	PWD
Bit 7		-		Device ID 7 (MSB)	RW	Reserved		1
Bit 6		-		Device ID 6	RW	Reserved		0
Bit 5		-		Device ID 5	RW	Reserved		0
Bit 4		-		Device ID 4	RW	Reserved		0
Bit 3		-		Device ID 3	RW	Reserved		0
Bit 2		-		Device ID 2	RW	Reserved		0
Bit 1		-		Device ID 1	RW	Reserved		1
Bit 0		-		Device ID 0	RW	Reserved		1



SMBus Table: Byte Count Register

Byte 6	Pin #	Name	Control Function	Type	0	1	PWD
Bit 7	-	BC7	Writing to this register configures how many bytes will be read back.	RW	-	-	0
Bit 6	-	BC6		RW	-	-	0
Bit 5	-	BC5		RW	-	-	0
Bit 4	-	BC4		RW	-	-	0
Bit 3	-	BC3		RW	-	-	0
Bit 2	-	BC2		RW	-	-	1
Bit 1	-	BC1		RW	-	-	1
Bit 0	-	BC0		RW	-	-	1



Note: Polarities in timing diagrams are shown OE_INV = 0. They are similar to OE_INV = 1.

PD#, Power Down

The PD# pin cleanly shuts off all clocks and places the device into a power saving mode. PD# must be asserted before shutting off the input clock or power to insure an orderly shutdown. PD is asynchronous active-low input for both powering down the device and powering up the device. When PD# is asserted, all clocks will be driven high, or tri-stated (depending on the PD# drive mode and Output control bits) before the PLL is shut down.

PD# Assertion

When PD# is sampled low by two consecutive rising edges of DIF#, all DIF outputs must be held High, or tri-stated (depending on the PD# drive mode and Output control bits) on the next High-Low transition of the DIF# outputs. When the PD# drive mode bit is set to '0', all clock outputs will be held with DIF driven High with $2 \times I_{REF}$ and DIF# tri-stated. If the PD# drive mode bit is set to '1', both DIF and DIF# are tri-stated.

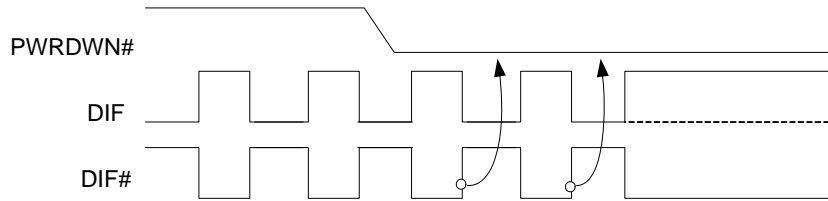

PD# De-assertion

Power-up latency is less than 1 ms. This is the time from de-assertion of the PD# pin, or VDD reaching 3.3V, or the time from valid SRC_IN clocks until the time that stable clocks are output from the device (PLL Locked). If the PD# drive mode bit is set to '1', all the DIF outputs must driven to a voltage of >200 mV within 300 ms of PD# de-assertion.

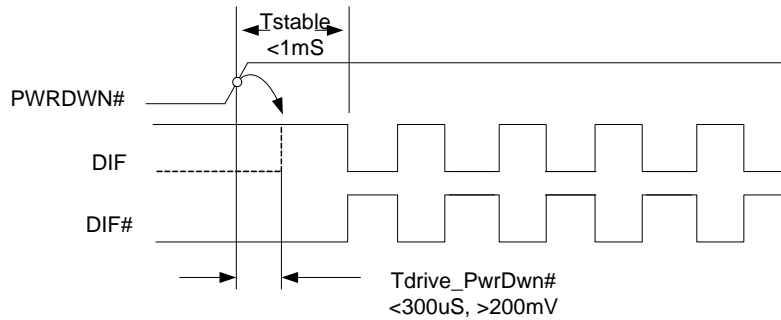

SRC_STOP#

The SRC_STOP# signal is an active-low asynchronous input that cleanly stops and starts the DIF outputs. A valid clock must be present on SRC_IN for this input to work properly. The SRC_STOP# signal is de-bounced and must remain stable for two consecutive rising edges of DIF# to be recognized as a valid assertion or de-assertion.

SRC_STOP# - Assertion

Asserting SRC_STOP# causes all DIF outputs to stop after their next transition (if the control register settings allow the output to stop). When the SRC_STOP# drive bit is '0', the final state of all stopped DIF outputs is DIF = High and DIF# = Low. There is no change in output drive current. DIF is driven with $6 \times I_{REF}$. DIF# is not driven, but pulled low by the termination. When the SRC_STOP# drive bit is '1', the final state of all DIF output pins is Low. Both DIF and DIF# are not driven.

SRC_STOP# - De-assertion (transition from '0' to '1')

All stopped differential outputs resume normal operation in a glitch-free manner. The de-assertion latency to active outputs is 2-6 DIF clock periods, with all DIF outputs resuming simultaneously. If the SRC_STOP# drive control bit is '1' (tri-state), all stopped DIF outputs must be driven High (>200 mV) within 10 ns of de-assertion.



SRC_STOP_1 (SRC_Stop = Driven, PD = Driven)

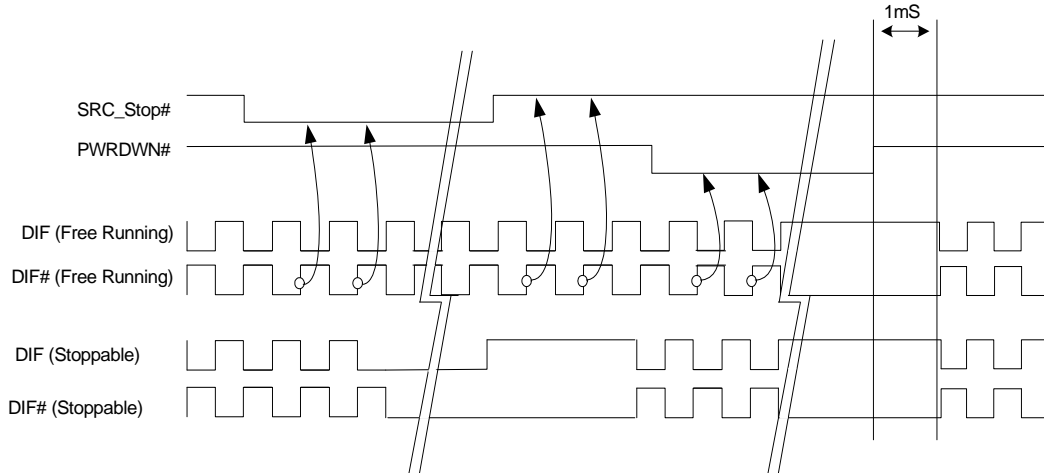

SRC_STOP_2 (SRC_Stop = Tristate, PD = Driven)

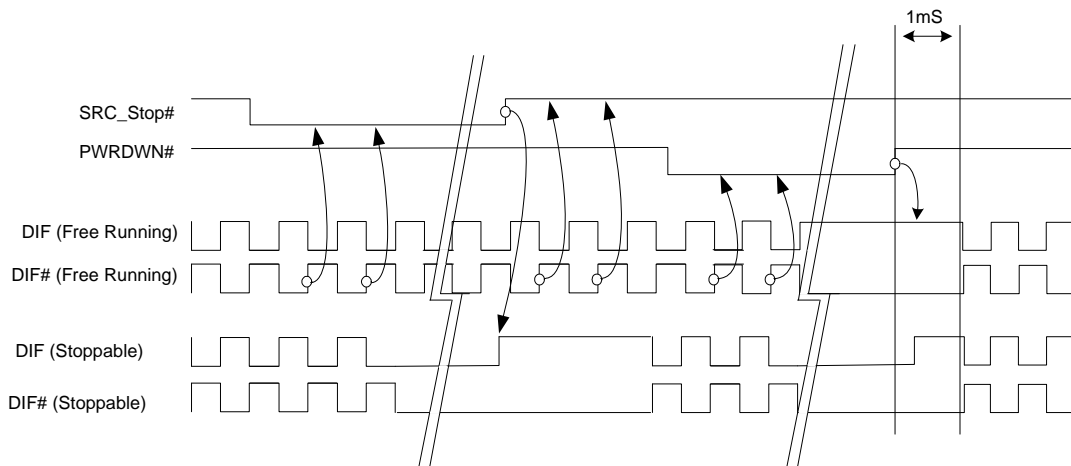



SRC_STOP_3 (SRC_Stop = Driven, PD = Tristate)

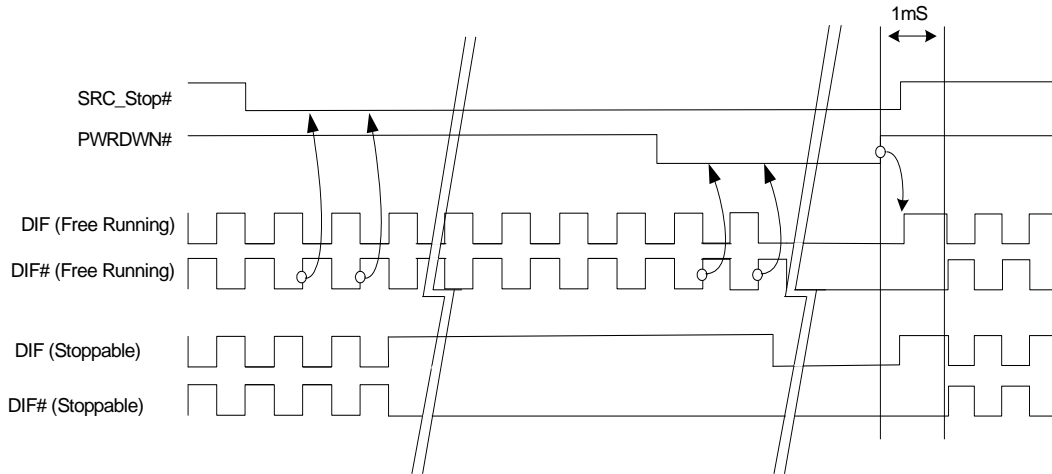

SRC_STOP_4 (SRC_Stop = Tristate, PD = Tristate)

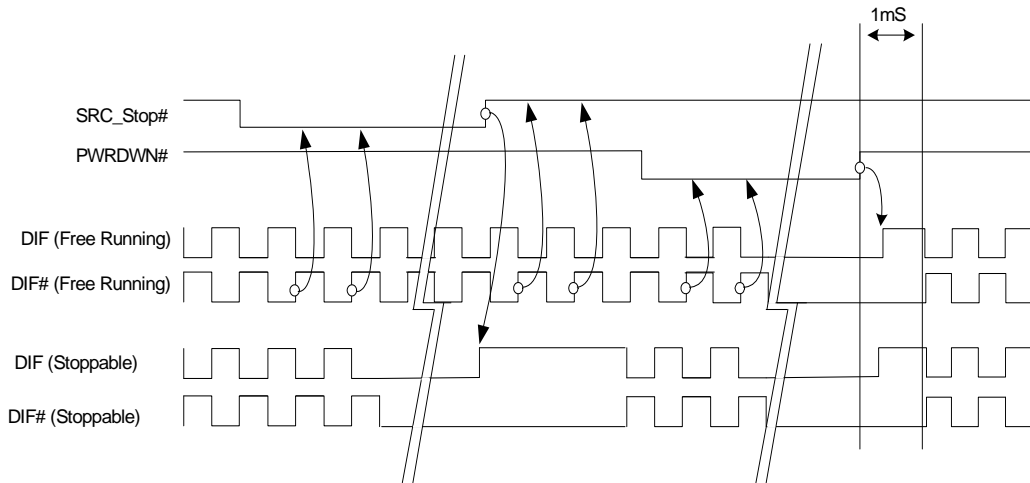

Silego Ordering Information

Part Number	Package Type	Temperature Range
SLG74803T	48 Lead Green Package TSSOP	Commerical, 0°C to 70°C
SLG74803TTR	48 Lead Green Package TSSOP - Tape and Reel	Commerical, 0°C to 70°C
SLG74803KT	48 Lead Green Package TSSOP	Industrial, 0°C to 85°C
SLG74803KTTR	48 Lead Green Package TSSOP - Tape and Reel	Industrial 0°C to 85°C



Package Drawings and Dimensions

48L TSSOP (6.10 mm body, 0.50 mm pitch) see other dimensions in the table below.
(56-pin drawing is shown for reference)

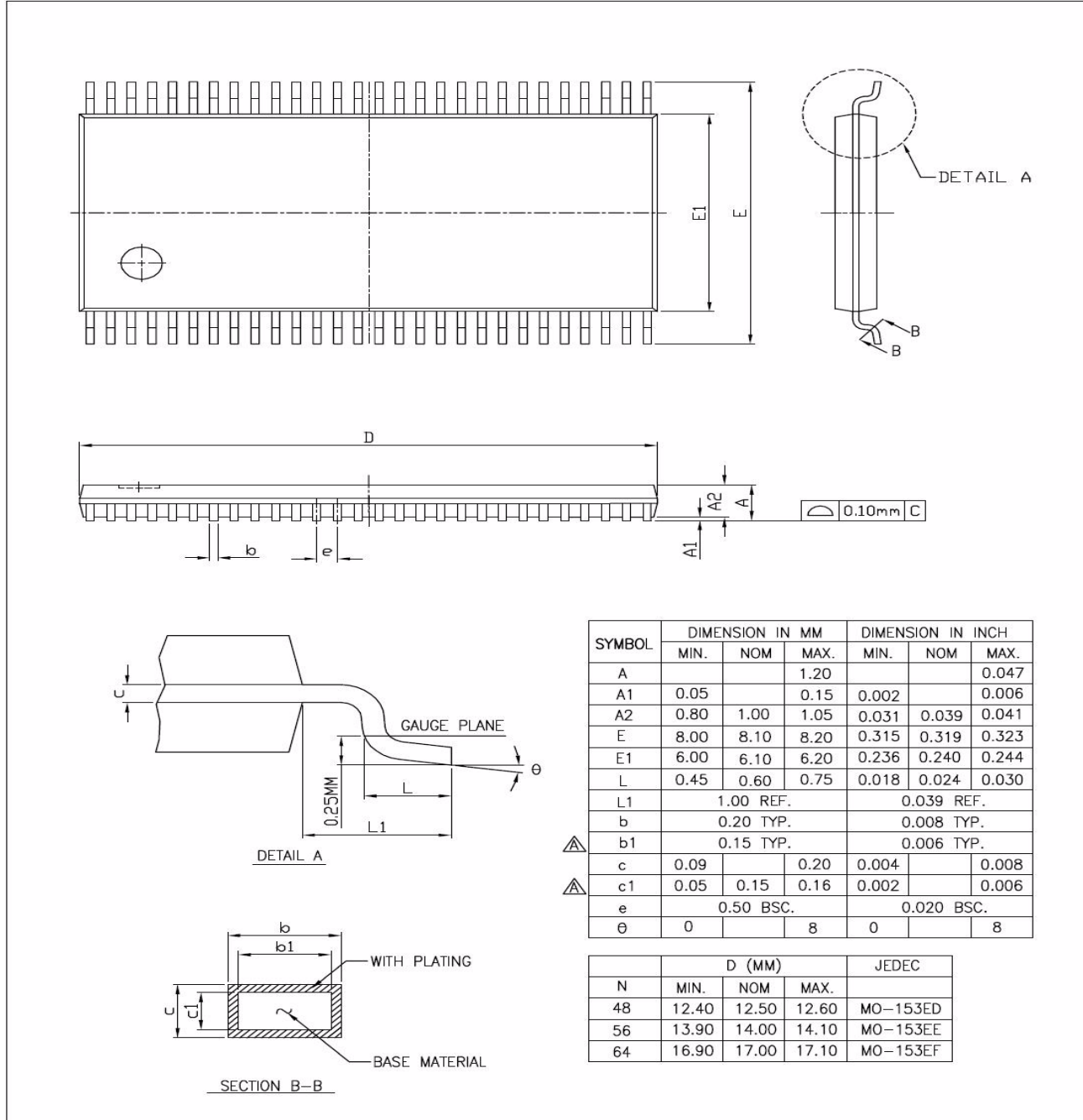

Silego Technology Inc. reserves the right at any time to change specifications and circuitry without notice. Silego Technology Inc. does not assume responsibility for use of circuitry described. Circuit patent licenses are not implied. Silego Technology Inc. products are not authorized for use as critical components in life support devices or systems without obtaining express written approval from the president of Silego Technology Inc. A component is a critical component if failure to perform affects safety, effectiveness, or causes failure of the life support system. These systems are intended for surgical implant into the body, or support or sustain life, or whose failure to perform when properly used can be reasonably expected to result in injury to the user.